

DDF6100D RADIO DIRECTION FINDER USER MANUAL

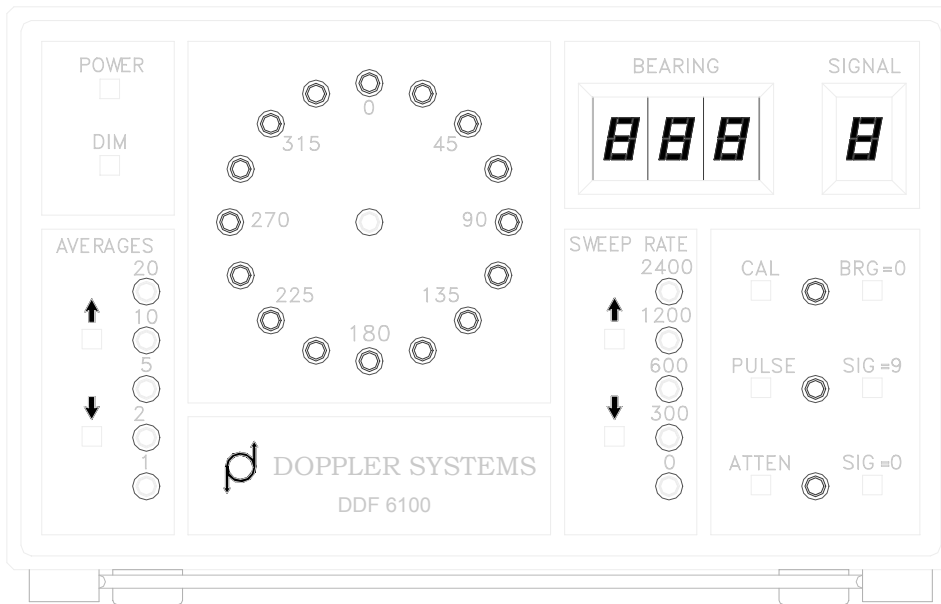

DOPPLER SYSTEMS INC.

PO Box 2780
37202 Bloody Basin Rd.
Carefree, Arizona 85377
Tel: (480) 488-9755
Fax: (480) 488-1295



Doppler Systems Inc.

European Union Declaration of Conformity Industrial Equipment



The EU Directives covered by this Declaration:

89/336/EEC Electromagnetic Compatibility Directive, amended by 92/31/EEC & 93/68/EEC

The Product Covered by this Declaration:

Doppler DDF6100 Radio Direction Finder (including Antenna and Accessories Models 6070, 6072, and 6073) Ser # SSSS
(S = 6001-7000)

The Basis on which Conformity is being Declared:

The product identified above complies with the requirements of the above EU Directives by meeting the following standards:

- * EN 50081-2(1994) "Electromagnetic Compatibility - Generic Emission Standard Part 2. Industrial Environment"
 - EN55022(1995) "Radiated Emissions Test", in accordance with the limits specified in EN55022(1995) for *Class B Devices*, and performed using the methods and procedures detailed in CISPR 22(1993) [including Correction #1 (Feb. 1995) and Amendment #1 (April 1995)], using instrumentation, equipment, and facilities in conformance with the requirements of CISPR 16-1(1993).
- * EN 50082-2(1995) "Electromagnetic Compatibility - Generic Immunity Standard Part 2. Industrial Environment"
 - IEC 801.2(1991) "Electrostatic Discharge [ESD] Immunity Test", performed in accordance with the instrumentation, equipment, facilities, limits [i.e. Criteria B], methods, and procedures specified therein (i.e. +/-8 kV Air Discharge [Level 3] and at all Lower Levels, and +/-4 kV Contact Discharge [Level 3] and at all Lower Levels).
 - ENV 50140(1994) "Radio-frequency Electromagnetic Fields Immunity Test", performed in accordance with the instrumentation, equipment, facilities, methods, procedures, and limits specified therein, (i.e. 3 V/m, with 80% AM Modulation at a 400 Hz rate, at both H and V Polarization, over the frequency range 80 MHz to 1000 MHz, Criteria A).
 - IEC 801.4(1988) "Electrical Fast Transients [EFT] Test", in accordance with the instrumentation, equipment, facilities, methods, procedures and limits [Criteria B] specified therein (i.e. Direct Injection of +/- 1 kV EFT on DC Input Ports, and Capacitive Clamp Injection of +/- 1 kV EFT on long (i.e. > 3 meters) Non-process Control I/O Lines, and Capacitive Clamp Injection of +/- 1 kV EFT on Process Measurement and Control Lines).
 - ENV 50141(1994) "Radio-frequency Common Mode Immunity Test", performed in accordance with the instrumentation, equipment, facilities, methods, procedures, and limits specified therein, (i.e. 3 Vrms, with 80% AM Modulation at a 400 Hz rate, over the frequency range 150 kHz to 80 MHz, Criteria A).
- * prETS 300 339(1993) "Radio Equipment and Systems (RES); Generic Electro-Magnetic Compatibility (EMC) for radio equipment"
 - EN55022(1995) "DC Conducted Emissions Test", in accordance with the limits specified in prETS 300 339(1993) and EN55022(1995) for *Class B Devices*, and performed using methods and procedures detailed in CISPR 22(1993) [including Correction #1 (Feb. 1995) and Amendment #1 (April 1995)], using instrumentation, equipment, and facilities in conformance with the requirements of CISPR 16-1(1993).
 - prETS 300 339(1993) "DC Voltage Variation Immunity Test" [Clause 9.5], in accordance with the instrumentation, equipment, facilities, methods, procedures and limits [Criteria B] specified therein (i.e. operate through under conditions of +/- 10% voltage variation in the DC input power).
 - prETS 300 339(1993) "DC Transients and Surges Immunity Test" [Clause 9.6], in accordance with the instrumentation, equipment, facilities, methods, procedures and limits [Criteria B] specified in ISO 7637-1(1990) (i.e. operate through ISO 7637-1(1990) Test Pulse #1, Test Pulse #2, Test Pulse #3a, Test Pulse #3b, Test Pulse #4, and Test Pulse #7, each as modified by prETS 300 339(1993) Clause 9.6).

The technical documentation required to demonstrate that this product meets the requirements of the EMC Directive has been compiled by the signatory below and is available for inspection by the relevant enforcement authorities. The CE mark was first applied in 1997.

Authority: Denis Egan
European Representative for Doppler Systems Inc.
PO Box 2 Seaton, Devon
EX12 2YS ENGLAND

Signature: 

Date: June 9th 1997

Telephone/Fax: 1297-62-56-90

Attention

The attention of the specifier, purchaser, installer or user is drawn to special measures and limitation to use, which must be observed when product is taken into service to maintain compliance with the above directives. Details of these special measures and limitations are in the product manual.

Warranty Information

Doppler Systems Inc. will repair or replace, at their option, any parts found to be defective in either materials or workmanship for a period of one year from the date of shipping. Defective parts must be returned for replacement. In the US, contact the factory, or overseas your local distributor, for advice about returning any defective parts or equipment.

If a defective part or design error causes your radio direction finder to operate improperly during the one year warranty period, Doppler Systems Inc. will service it free of charge if returned at owner's expense. If improper operation is due to an error on the part of the purchaser, there will be a repair charge.

Doppler Systems Inc. are not responsible for damage caused by the use of improper tools or solder, failure to follow the printed instructions, misuse or abuse, unauthorized modifications, misapplication of the unit, theft, fire or accidents. This warranty applies only to the equipment sold by Doppler Systems Inc. and does not cover incidental or consequential damages.

Doppler Systems radio direction finding equipment is designed to be used for the location of interfering radio signals. **It is not intended to be used as a navigation aid, and in particular it is not to be used for aircraft or marine navigation.**

Accessories Included

- (1) User Manual
- (1) 12 VDC, 1.5 amp, 110 VAC wall mount power supply (North American models)
- (1) DC power cable DDF6110 (automobile cigarette lighter plug to 2.5 mm plug)
- (2) 3.5 mm phone jack to 3.5 mm phone jack cable #40DK40
- (1) 3.5 mm phone jack to RCA phono jack cable #40DK25
- (2) 3.5 mm phone jack #750
- (1) Serial data cable, DDF6161-6
- (1) Auto Track Software disk and manual
- (1) Test Software disk

Table of Contents

1.0 Introduction	1
2.0 Specifications	2
3.0 Controls and Connectors	3
4.0 Installation	7
4.1 Homing Installation (no GPS).....	7
4.2 Auto Triangulation Installation (with GPS)	9
4.3 Interaction from Other Antennas	10
4.4 Phone Jacks.....	11
4.5 ICOM R7000 Receiver Modifications for S-meter Output.....	11
5.0 Operation.....	19
5.1 Initialization	19
5.2 Calibration.....	19
5.3 Direction Finding in the Continuous Mode (Pulse Mode OFF)	19
5.4 Direction Finding in the Pulse Mode.....	21
5.5 Homing.....	21
5.6 Auto Triangulation	21
6.0 Serial Interfaces.....	23
6.1 Introduction	23
6.2 Hardware Interfaces.....	23
6.3 Message Protocol.....	24
6.4 Multiplexing and Control Characters	27
7.0 Test Software	33
8.0 Servicing	34
8.1 Schematics	34
8.2 EPROM Replacement.....	34

1.0 Introduction

The DDF6100 is a high performance radio direction finding system that operates using the simulated Doppler principle. Four omni directional antennas are arranged in a circular array and are connected to an RF combining or summer circuit. The summer combines the antenna signals in a way which simulates the continuous rotation of a single antenna element about the axis of symmetry of the antenna array.

As the simulated element approaches the wave front of an RF signal, the frequency increases due to the Doppler effect, and as it recedes from the transmitted source, the frequency decreases. The amount of frequency change (deviation) is related to the speed of rotation and the diameter of the antenna array, while the modulation frequency is equal to the frequency of rotation (the antenna sweep frequency). When connected to a narrow band communication receiver, the sweep frequency is present on the audio output. To obtain the bearing angle, the direction finder processes this audio output.

Many features are present in the DDF6100:

- C The unit may be used as a standalone radio direction finder for homing on a signal, or it may be used with the supplied Auto Track software program and a compatible GPS receiver to triangulate.
- C The sweep frequency may be set to 300, 600, 1200 or 2400 Hz to avoid tone frequencies that may be present in the signal modulation.
- C Advanced signal processing is used to detect the signal with the receiver either squelched or unsquelched. Both continuous and 150 millisecond pulsed signals can be processed.
- C The sweep direction automatically changes from clockwise to counterclockwise and back to compensate for asymmetries in the receiver.
- C An internal audio amplifier and loudspeaker are provided for monitoring the signal, and a sharp notch filter removes the sweep frequency tone for clarity.
- C When used with the supplied Auto Track software program, the direction finder provides a serial data multiplexer between the laptop computer and up to four external devices. One of the four serial ports is configured for CIV bus operation and the other three are RS232.
- C The display is housed in an attractive metal enclosure to enhance electromagnetic compatibility (EMC).
- C Accessories available include a low profile roof top antenna pod, an RF summing unit, power distribution unit, compatible GPS receiver and electronic compass.

2.0 Specifications

Performance specifications apply to a DDF6100 when connected to the roof pod antenna (DDF6073), RF summing unit (DDF6070) and a narrow band fm receiver such as the ICOM R7000, R7100, or R8500.

Frequency range	88-1000 MHZ using appropriate length whips and antenna spacing.
Bearing display	16 LED circle and 3 digit LED display
Bearing display rate	2 Hz
Bearing accuracy (1 sigma)	5 degrees
DF sensitivity (typical)	-130 dBm, continuous signal -126 dBm, pulsed signal
Bearing averaging (selectable)	1, 2, 5, 10 or 20 samples
Antenna sweep rate	300, 600, 1200 or 2400 Hz
RF attenuator (selectable)	0 or 20 dB
Audio input range	0.01 to 0.6 VRMS
Audio output	0.5 watts maximum
S-meter input range	-10 to +10 VDC
Serial interfaces	(1) DCE RS232 port for laptop (3) DTE RS232 port for GPS, compass, etc. (1) CIV port for receiver
Power requirement	11 to 14 VDC
Current consumption	1.0 amp
Operating temperature (display)	0 to 50 degrees C
Dimensions (display - HxWxD)	108x171x235 mm (4.25x6.75x9.25 in)
Weight (display)	1.9 Kg (4.1 lbs)

3.0 Controls and Connectors

Figure 3-1 on shows the front panel controls and figure 3-2 shows the rear panel connectors. The items marked ▲ in the following paragraphs refer to the controls and connectors in these figures.

- ▲1 Press the red power switch to turn the unit on or off.
- ▲2 The front panel LEDs may be dimmed by momentarily pressing this switch. Pressing it again returns the LEDs to full brightness.
- ▲3 Bearing data is computed twice per second. The front panel displays a moving average of the last N bearings calculated. The number of bearings averaged, N, may be increased or decreased by pressing the up or down arrow keys.
- ▲4 The bearing is displayed by illumination of one of the red LEDs on the circular display. The center yellow LED indicates that power is on.
- ▲5 Bearing angles in degrees are displayed in the 7-segment display. Both the circular LED display and the digital display are held for 10 seconds after the signal disappears. To help distinguish when the bearing is updating and when it is being held, the decimal point following the units digit alternates on to off whenever the bearing updates.
- ▲6 The signal strength is indicated in this 7-segment display. It should be calibrated so that the signal strength is 0 when no signal is present and 9 when a very strong signal is present. See the description of controls ▲8, ▲10 and ▲11 for the method of calibrating the S-meter. The S-meter displays a dash if the S-meter input is not connected or if the display has not been calibrated.
- ▲7 The antenna rate of rotation can be increased or decreased by pressing the up or down arrows here. When a sweep rate of 0 is selected, all antennas are turned ON. This mode is useful in detecting a very weak signal, but bearings are not displayed.
- ▲8 This switch enables or disables the calibration mode. The calibration mode must be enabled for the bearing and s-meter calibration switches to be effective.
- ▲9 Pressing this switch when the calibration mode (see ▲8 above) is enabled causes the present bearing to be set to 0 degrees. Momentarily pressing this switch when the calibration mode is not enabled causes the present bearing to be incremented by 1 degree. If the switch is held down, the bearing increments in steps of 10 degrees.
- ▲10 This switch calibrates the S-meter to 9 on the present signal, provided the calibration mode is enabled (see ▲8 above).

- ▲11 This switch calibrates the S-meter to 0 on the present signal, provided the calibration mode is enabled (see ▲8 above).
- ▲12 Pressing this switch changes the direction finder alternately from the Continuous and Pulse mode and back. The DF should be used in the Continuous mode on most signals (voice, unmodulated carriers, etc.) and in the Pulse mode when the signal is known to be on for 150 milliseconds every 0.5 or more seconds.
- ▲13 This switch causes a 20 dB attenuation of the RF input to the commutation electronics.
- ▲14 J1, Port #0 RS232 serial interface configured as a DCE. May be connected directly to PC using a 9 pin male to 9 pin female straight-through cable. See section 6.2.1, for details of this interface.
- ▲15 J2, Port #2 RS232 serial interface configured as a DTE. May be connected to GPS or compass RS232 output. See section 6.2.2, for details of this interface.
- ▲16 J3, receiver audio input. Connect to the external speaker output of your receiver using the supplied 3.5 mm to 3.5 mm cable or make a custom cable using the supplied 3.5 mm plug.
- ▲17 J4, Port #1 CIV interface. May be connected to the CIV remote control interface on your receiver using the supplied 3.5 mm to 3.5 mm cable. See section 6.2.3, for details of this interface.
- ▲18 J5, S-meter input. Connect to the receiver's S-meter output using the supplied 3.5 mm to RCA phono jack cable or make a custom cable using the supplied 3.5 mm plug.
- ▲19 J6, external speaker output. May be connected to an external speaker (not supplied) using a 3.5 mm plug.
- ▲20 J7, DC power input. Connect to +12 VDC using the supplied 2.5 mm cable, or on North American models from the supplied 110 vac power supply.
- ▲21 J8, antenna control cable output. Connect to the 15 pin cable supplied with RF summers DDF6060 or DDF6070.
- ▲22 J9, antenna switch output. (Not used in DDF6100).
- ▲23 J10, auxiliary input. (Reserved for future expansion).
- ▲24 J11, Port #3 RS232 serial interface configured as a DTE. May be connected to GPS or compass RS232 output. See section 6.2.2, for details of this interface.
- ▲25 J12, Port #4 RS232 serial interface configured as a DTE. May be connected to GPS or compass RS232 output. See section 6.2.2, for details of this interface.

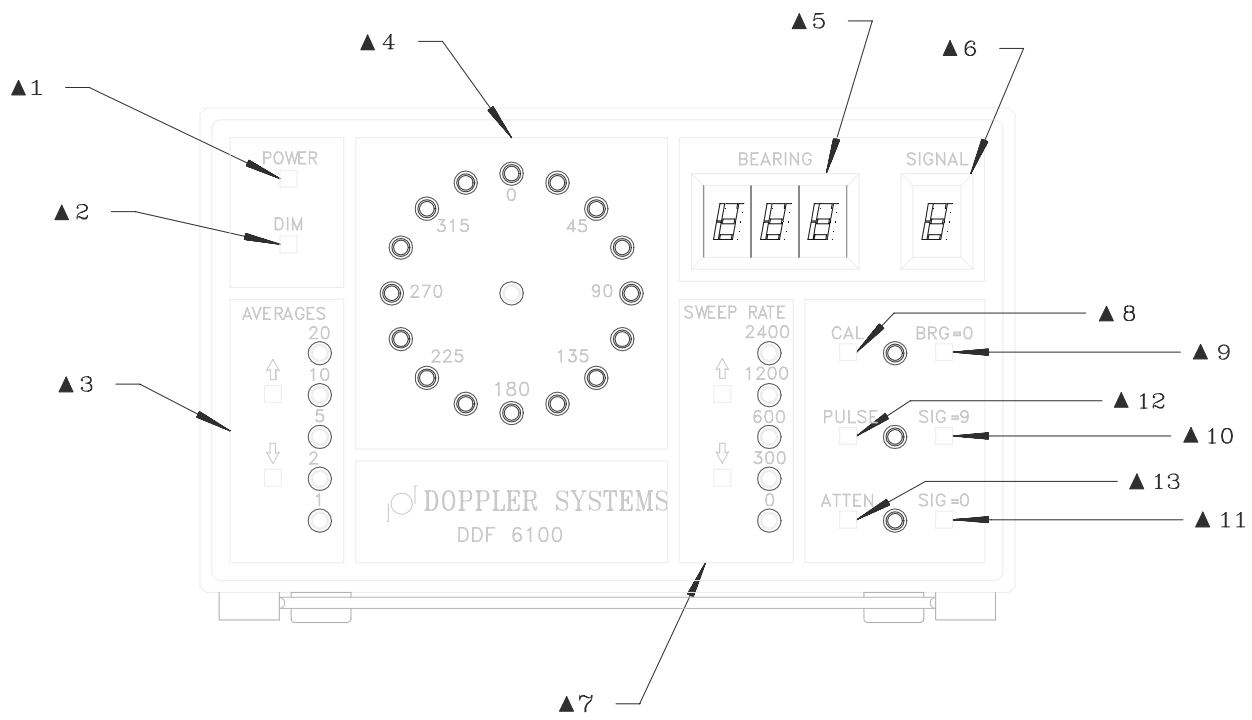

Figure 3-1
Front Panel Controls

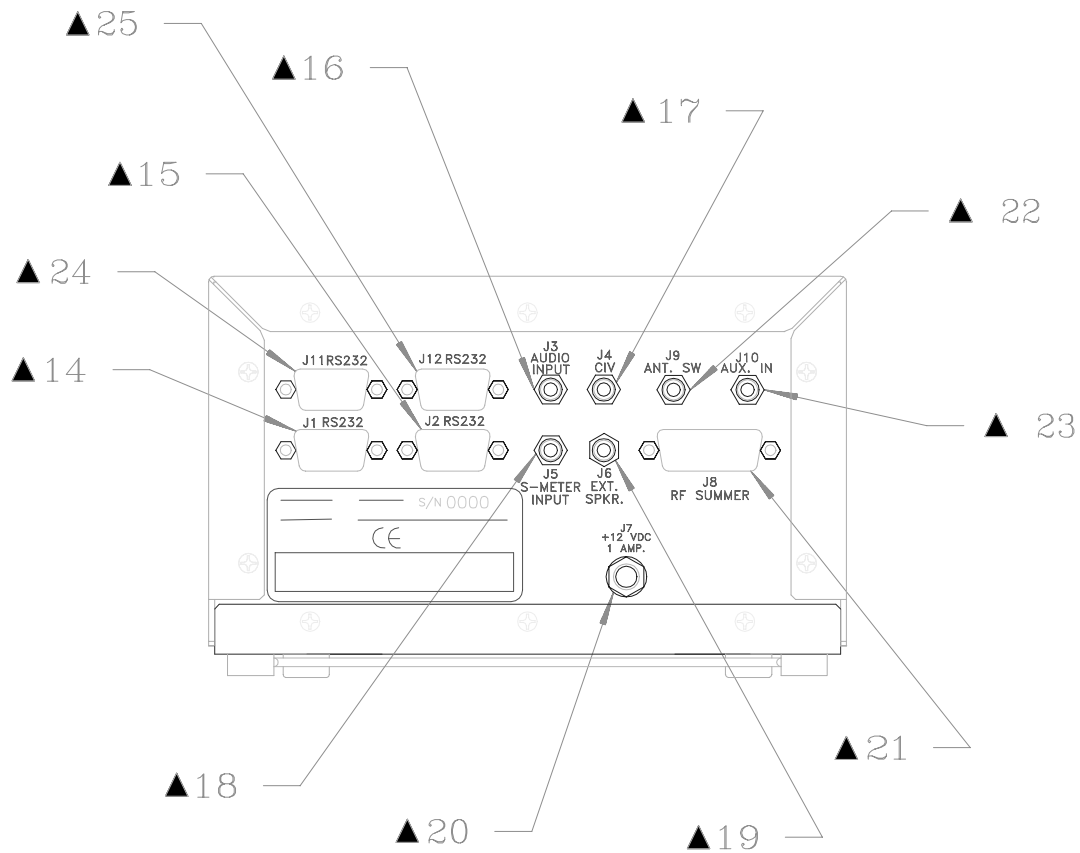

Figure 3-2
Rear Panel Connectors

4.0 Installation

4.1 Homing Installation (no GPS)

The DDF6100 can be used in a stand alone configuration in which the relative bearing is displayed on the front panel. The laptop computer, GPS, compass, and power distribution box are not used. The roof pod antenna, DDF6073 may be used with RF summer DDF6070, or the system can also be used with individual antennas (DDF6061, 6062, 6067 and 6068) and the magnetic mounted RF summer DDF6060. Figures 4-1 and 4-2 show the connections required between the various components used in the homing setup.

4.1.1 Antenna Installation (with Roof Pod)

The roof pod antenna provides a convenient platform for mounting all of the antennas and the RF summer. Referring to Figure 4-3, assemble the roof pod as follows:

Mount the RF summer DDF6070 ▲ 11 below the ground plane in the center of the platform using the four 6-32x5/16 screws provided with the summer. Connect the coax cable and control cable supplied with the RF summer and route these out through one of the rectangular holes on one of the rear support brackets.

From the following table, locate the antenna elements and mounting locations for the frequency you will be using and mount the antennas.

Frequency (MHZ)	Antenna Elements ▲ 13	Antenna Mounts
88-108 (WBFM)	686 mm (27 inch) whips	5/16-24 stud mounts on 538 mm (21.2 inch) square ▲ 4
108-136 (AM)		
125-175 (NBFM)	445 mm (17.5 inch) whips	5/16-24 stud mounts on 269 mm (10.6 inch) square ▲ 3
175-250 (NBFM)		
250-350 (NBFM)	152 mm (6 inch) whips	5/16-24 stud mounts on 135 mm (5.3 inch) square ▲ 2
350-500 (NBFM)		
500-700 (NBFM)	73 mm (2.875 inch) stubs	TNC mounts on 50.8 mm (2.0 inch) square ▲ 1
700-1000 (NBFM)		

Connect the coax jumper cables with the right angle TNC connectors ▲7. If you are using the antenna in the 700-1000 MHZ range, these cables are not used; otherwise connect one end of each cable to a TNC connector on the RF summer. Connect the other end to the TNC connector that corresponds to the small, middle or large antenna mounting square. (See Figure 4-3).

Set the ground plane on the car roof with the RF summer cables at the rear of the car. Run the cable straps ▲11 through the door frames (or windows) and fasten them securely inside the car. See Figure 4-4. Set the cover ▲14 down over the ground plane and fasten it with the four latches ▲12. Be sure that the cover is firmly attached to the car before driving. Route the cables from the RF summer through a rear window.

4.1.2 Antenna Installation (without Roof Pod)

Four antenna elements are used for mobile operation. At frequencies below 500 MHZ, magnetically mounted quarter wave whips are used. These antennas must provide a good coupling to the ground plane, and must be of exactly the same type. It is especially important that the coaxes used have the same length.

Doppler Systems antennas DDF6061, 6062, and 6068 all use the same magnetic mount base and cover the frequency ranges 88-136, 136-500, and 52-88 MHZ respectively. Cut the whips to resonance using the chart provided with the antennas and space them between 1/8 and 1/4 wavelength apart on the car's roof. **To avoid damage to the input circuitry used in the RF summer, touch the antenna ground plane before attaching the whips to the magnetic mounts.** It is important that the vehicle provides at least 1/4 wavelength of ground plane outboard of the antennas.

Place the RF summer (DDF6060) on the car with the cables oriented towards the rear of the car. Connect the magnetic mount antenna cables to the corresponding TNC connectors on the RF summer. (That is, the left front antenna to the left front connector, etc.) Locate the summer near the back of the car (the lid of the trunk or boot) so that the magnetic mount antenna cables do not have excessive slack. Secure the four antenna cables together with nylon ties so that they are not free to move around and touch the antenna elements. Route the control and RF cables through a rear window.

For mobile operation in the 700-1000 MHZ band, antenna DDF6067 should be mounted directly on top of the RF summer. This antenna provides an extended ground plane, a wind shroud, and four stub type antennas built into TNC connectors. Place the assembled RF summer/antenna in the center of the car roof. Be sure to use the safety strap provided with the DDF6067 antenna.

4.1.3 Receiver and Direction Finder Connections

Place the DDF6100 and the receiver where they are easy to operate and connect the coax cable from the RF summer to the receiver's antenna connector and the control cable from the RF summer to J8 on the direction finder. See Figure 4-1 or 4-2. Connect the receiver's external speaker output to J3 on the direction finder using one of the 3.5 mm cables supplied, and connect the receiver's AGC output (if available) to J5 using the 3.5 mm to phono plug cable supplied. The AGC output is available on the ICOM R7100 and R8500 receivers; if you are using the R7000, you can add it to the Spare output connector as described in paragraph 4.5 below.

The DF power is supplied to J7 from the cigar lighter using cable DDF6110. If you want to power the receiver from the same outlet, use a "Y" adapter.

4.2 Auto Triangulation Installation (with GPS)

The system may be arranged for automatic triangulation with or without the roof pod antenna. The roof pod is preferred because it supports the direction finding antennas, GPS antenna and (if used) the compass. Figures 4-5 and 4-6 show the connections required with and without the roof pod.

4.2.1 Antenna Installation (with Roof Pod)

Assemble the roof pod direction finding antennas as discussed in section 4.1.1 above.

Mount the GPS antenna at one of the four corners of the platform ▲9. Use the four 4-40x1/4 screws provided. Usually it is best to mount it near the front of the vehicle and the compass if used at the rear, but this can be varied to suit your vehicle. Route the cable through the hole in the plate next to the antenna then out through the rectangular hole used for the other cables at the rear standoff bracket.

If you are using the compass, DDF6075, mount it at one of the two locations ▲10 along the front or rear of the ground plane. Usually the location near the rear is best. Use the two 10-32x3/8 screws provided. Route the compass cable through rectangular slot in the plate next to the compass, then out through the rectangular hole used for the other cables at the rear standoff bracket. The pod provides about 50 mm (2 inches) of clearance between the compass and the car's steel roof, which should be adequate to avoid serious distortion of the Earth's magnetic field. If during the calibration of the compass, you get a poor environmental "scoring", try moving the compass to the alternate location at the front of the ground plane.

Tie the cable bundle together using some nylon ties when you are satisfied with the routing.

4.2.2 Antenna Installation (without Roof Pod)

Mount the direction finding antennas and RF summer on the roof as described in section 4.1.2 above.

Place the GPS antenna on the car roof. Put it at least 0.3 m (1 ft) away from the direction finding antennas and route its cable through the open window used for the other cables.

You cannot use the compass without the roof pod.

4.2.3 Receiver, Direction Finder, Laptop Computer, and Power Distribution

You will need to assemble two simple cable assemblies yourself to supply 12 VDC to your receiver and laptop computer via the power distribution box, DDF6072. The connectors required are provided with the DDF6072 and the wiring is shown in Figure 4-7.

Place the DDF6100, the communications receiver, the GPS receiver and the power distribution box in the rear seat of the car, and the laptop computer in the front. Connect the coax cable from the rf summer to the receiver's antenna connector and the control cable from the RF summer to J8 on the direction finder. See Figure 4-5 or 4-6. Connect the receiver's external speaker output to J3 on the direction finder using one of the 3.5 mm cables supplied, and connect the receiver's AGC output (if available) to J5 using the 3.5 mm to phono plug cable supplied. The AGC output is available on the ICOM R7100 and R8500 receivers; if you are using the R7000, you can add it to the spare output connector as described in paragraph 4.5 below.

Connect the laptop serial port to J1 on the DDF6100 using the 1.8 m (6 ft) cable, DDF6161-6 supplied with the direction finder. Connect the serial port on the GPS receiver to J11 on the direction finder using the 0.6 m (2 ft) cable, DDF6161-2 supplied with the GPS receiver, DDF6074. Connect the serial cable from the compass, if used, to J12 on the direction finder.

Connect the power cables from the power distribution box DDF6072 as shown in Figures 4-5 or 4-6.

When disassembling the equipment, it is a good idea to leave the GPS receiver connected to the power distribution box (J2). This is because the power box contains a Lithium battery that is used to maintain the status of the GPS, and it will permit the system to reacquire the satellites much faster.

4.3 Interaction from Other Antennas

It is a good idea to remove any other antenna from the car when using the direction finder to avoid its affecting the accuracy of the system. If you need to use another antenna, try experimenting with its location to minimize the coupling with the DF antenna.

It is possible to damage the RF summer if more than a few hundred milliwatts of RF power is induced into its input. The preamps used are rated at 100 milliwatts maximum input and we provide additional protection that increases the rating to about 2 watt. Transmitting 10 or more watts from a mobile antenna a few feet away in the same band will probably damage the unit while transmitting 5 watts inside a car will not. Transmitting a few watts from a nearby antenna on a different band from the direction finder antenna will probably not hurt the unit. Vertical separation helps also, so if you can place the transmit antenna on the trunk lid or boot of a car and the DF antenna on its roof, the coupling will be greatly reduced. When in doubt, it is best to run a test by connecting a mobile antenna output into an RF power meter and checking the power induced from the transmitter. If it is more than 100 milliwatts, relocate the transmit antenna.

4.4 Phone Jacks

The phone jacks used on the DDF6100 are Switchcraft ATini-Jax@connectors. These are commonly referred to as 3.5 mm connectors, but they actually measure 3.58 mm (0.141 inch) diameter. Other 3.5 mm connectors such as are used on ICOM receivers measure closer to 3.50 mm (0.138 inch) diameter. For reliable operation, mating plugs must be Switchcraft Type 750, which are supplied with the DDF6100. These plugs mate with the 3.5 mm jacks used on the ICOM receivers, but the ICOM 3.5 mm plugs do not reliably mate with the Switchcraft Tini-Jax connectors used in the DDF6100.

Cables 40DK40 (3.5 mm to 3.5 mm) and 40DK25(3.5 mm to RCA plug) are built with the Switchcraft 750 style plug.

4.5 ICOM R7000 Receiver Modifications for S-meter Output

The ICOM R7000 can easily be modified to provide an S-meter output for the DDF6100. Remove the top cover and locate the Main Unit PWB on the left side of the receiver and the spare RCA phono jack (J7) on the rear panel. Solder a 5.1 K resistor to the center pin of J7 and solder an insulated wire to the other end of the resistor. Route the wire to the topside of the Main Unit and carefully solder the other end of the wire to pin 1 of IC4. IC4 is an 8 pin DIP op amplifier type NMJ4558D. (Solder the wire directly to the IC lead using a minimum amount of heat and a very small tip iron).

On the ICOM R7100 or R8500, you can connect the S-meter input directly to the AGC output jack.

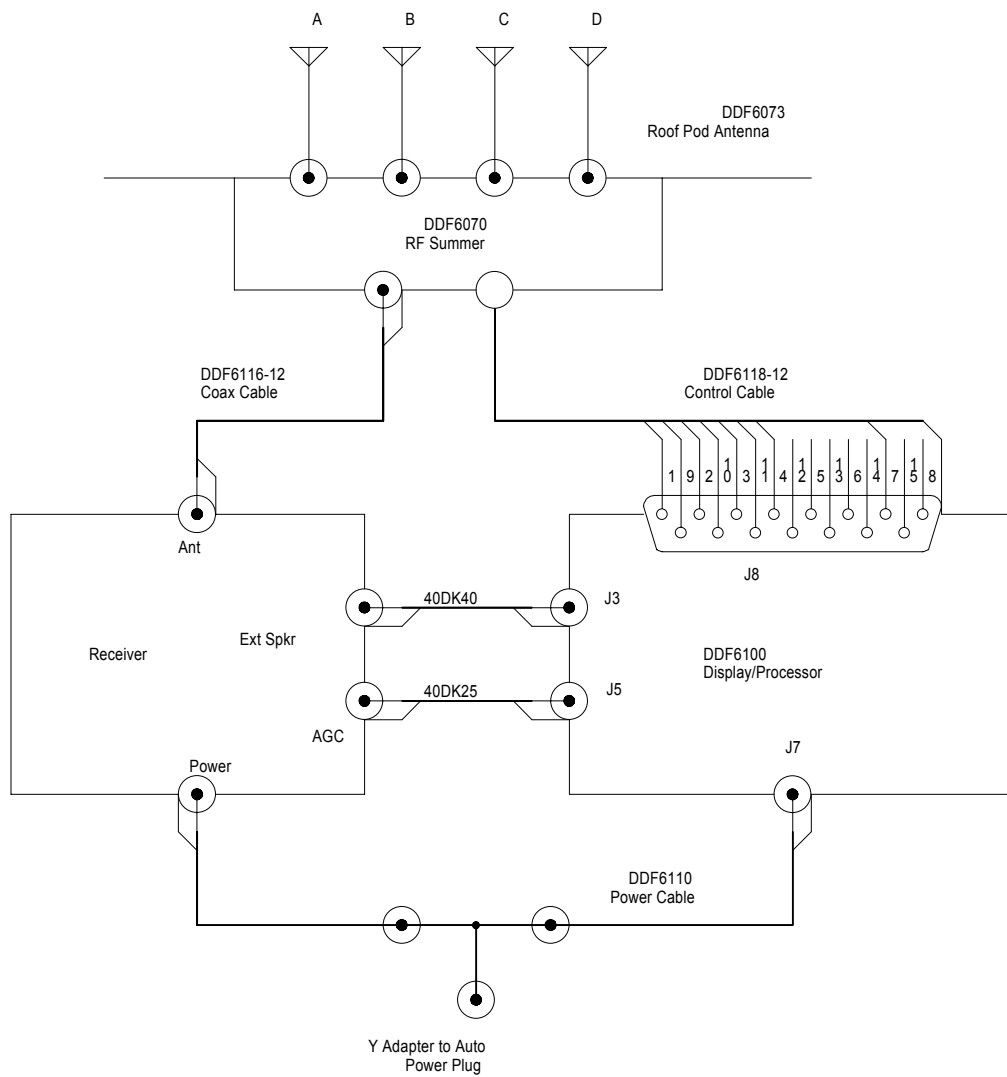

Figure 4-1
Cabling for Homing with Roof Pod

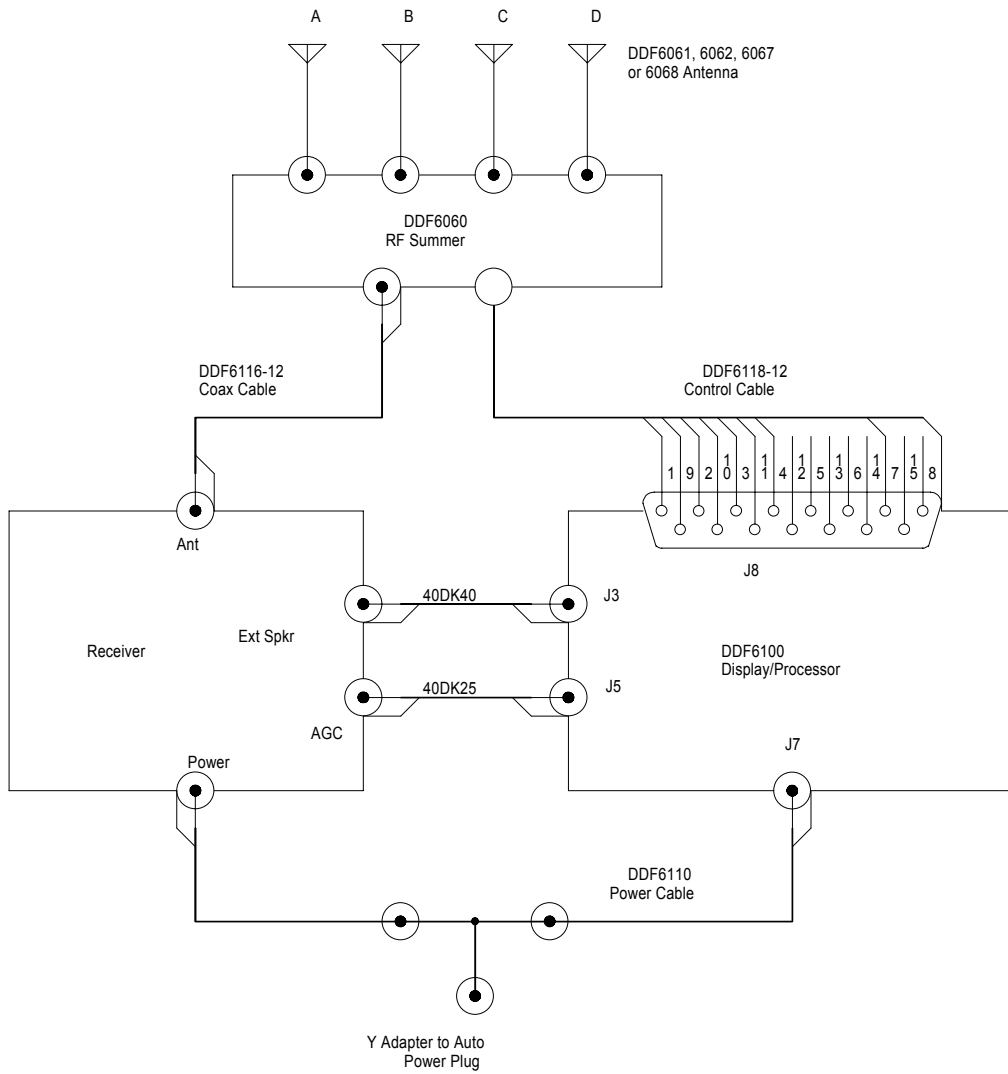

Figure 4-2
Cabling for Homing without Roof Pod

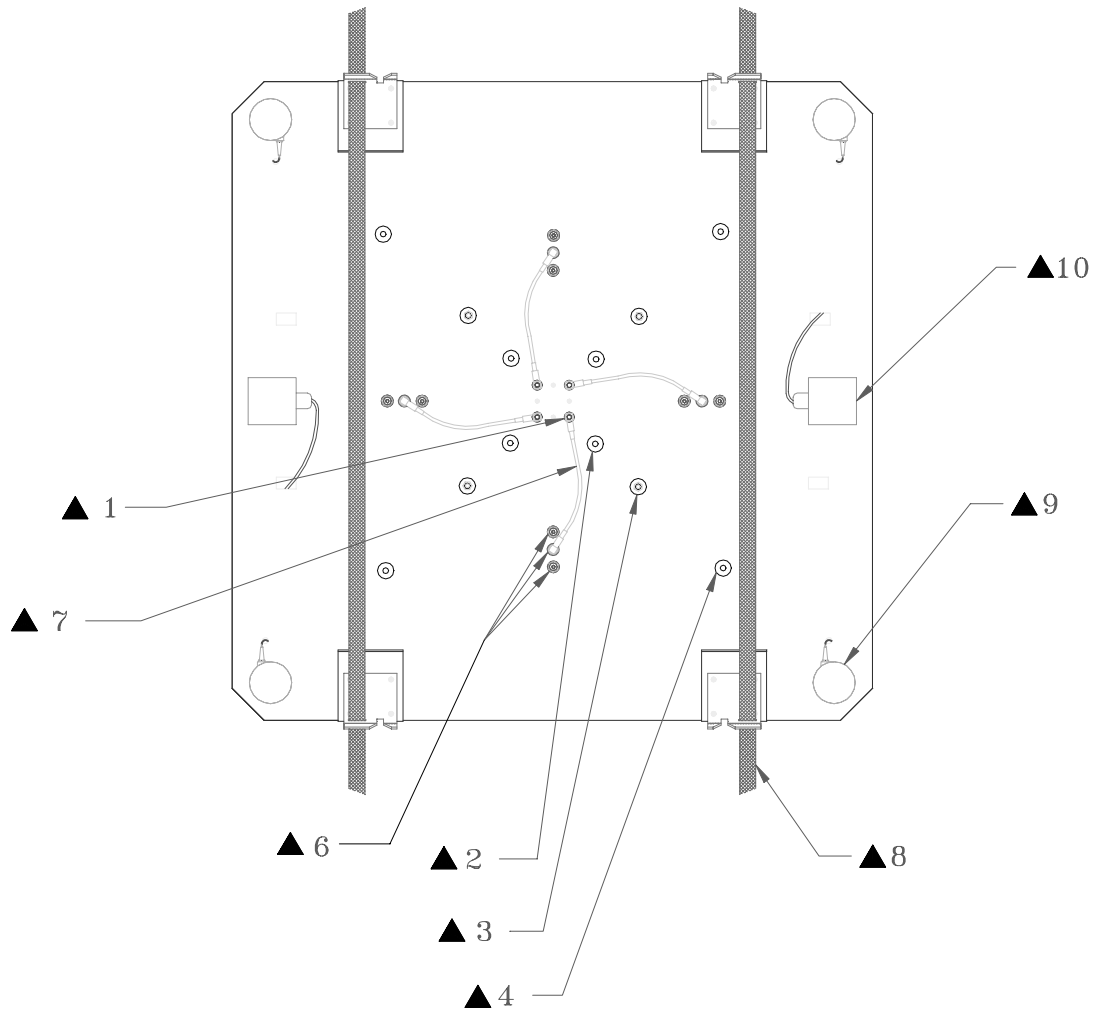

Figure 4-3
Roof Pod Antenna Top View

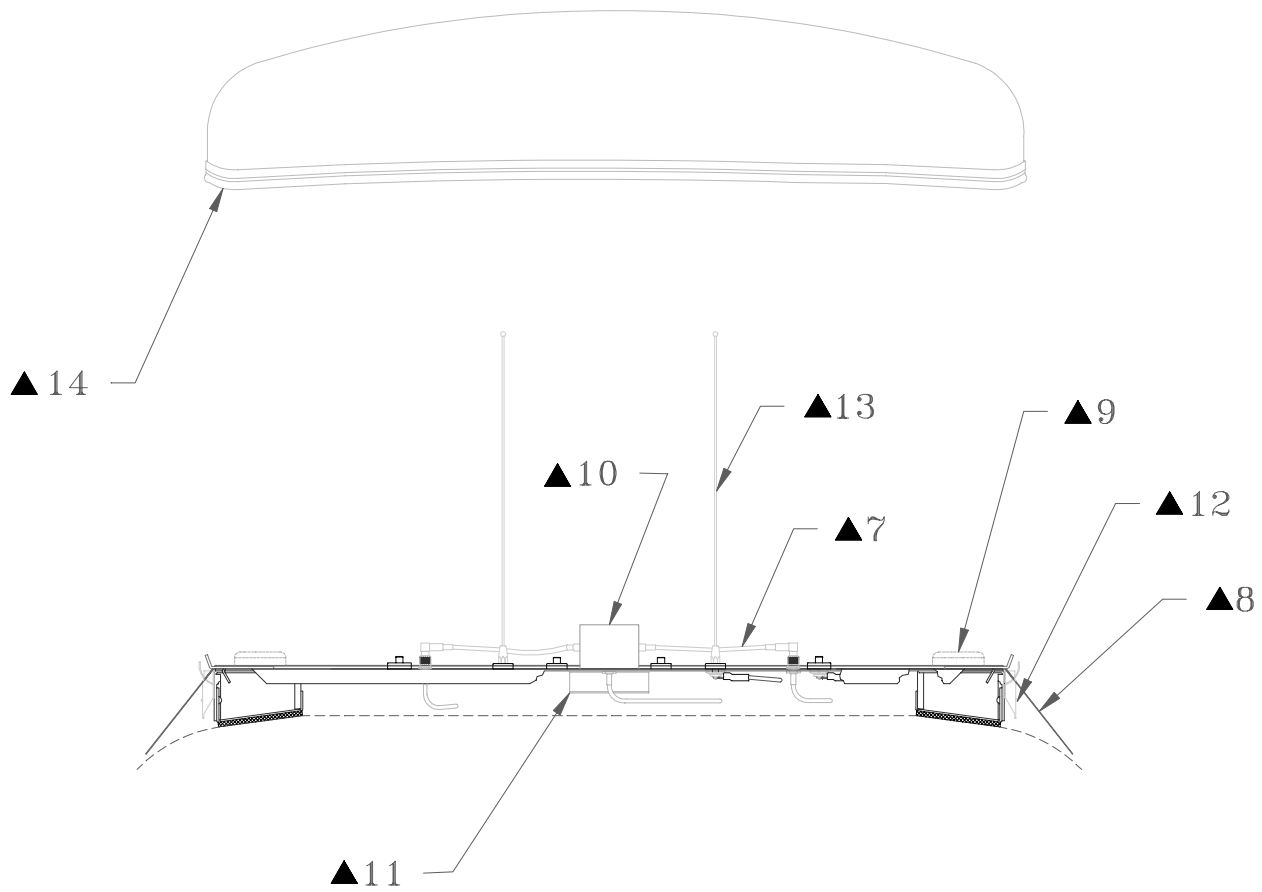
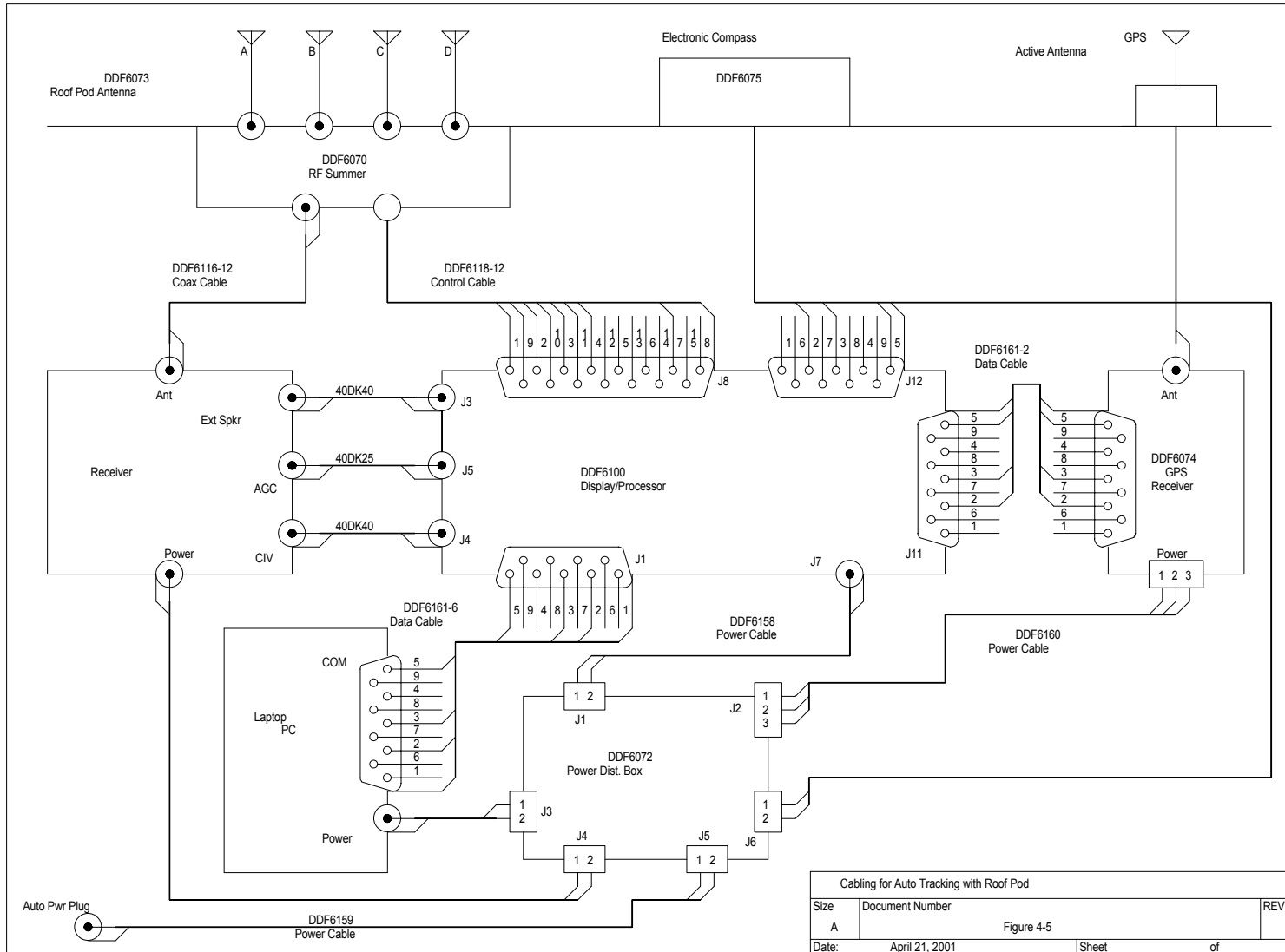
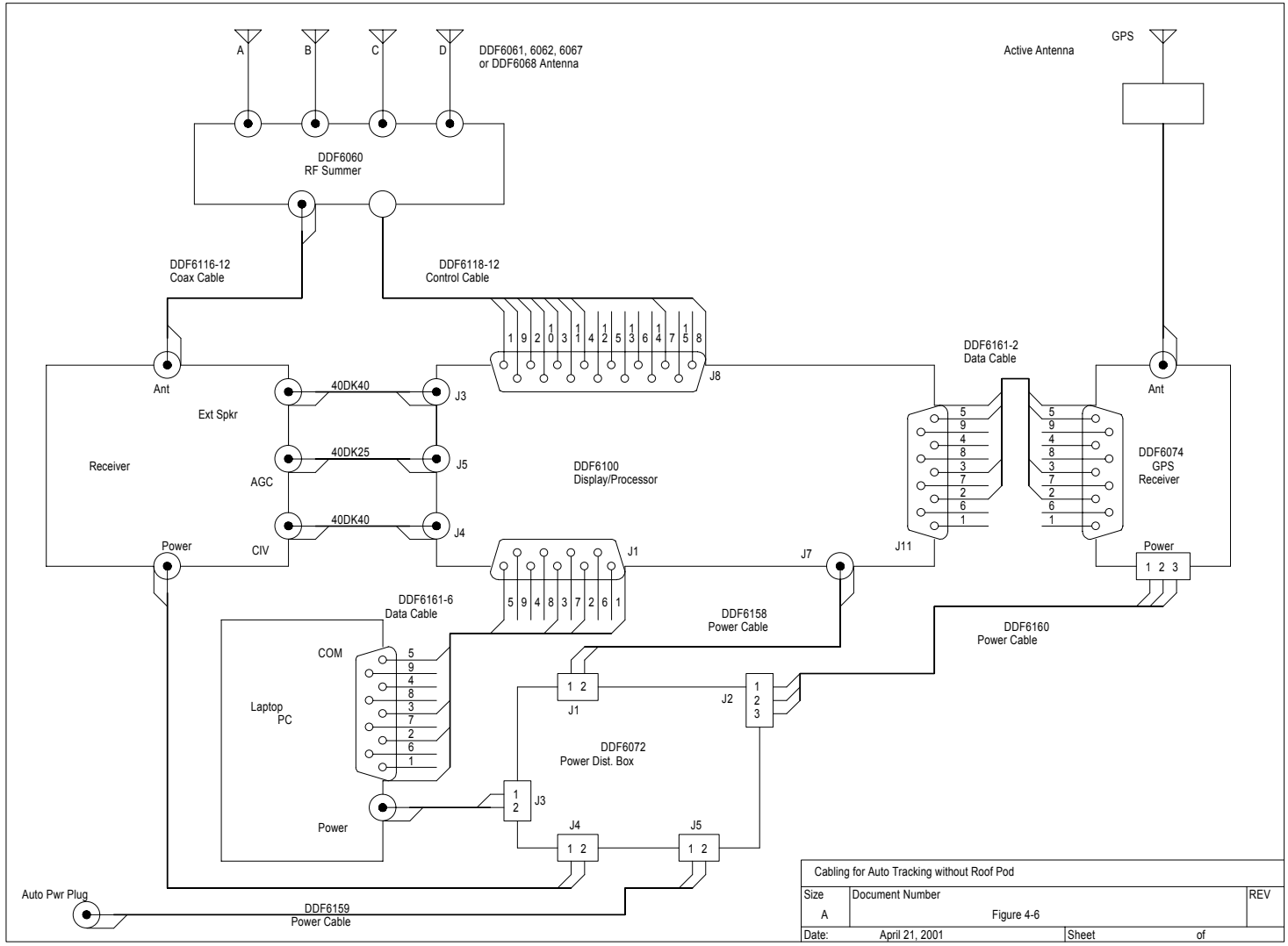

Figure 4-4
Roof Pod Antenna Side View



Cabling for Auto Tracking with Roof Pod

Size	Document Number	REV
A	Figure 4-5	
Date:	April 21, 2001	Sheet of



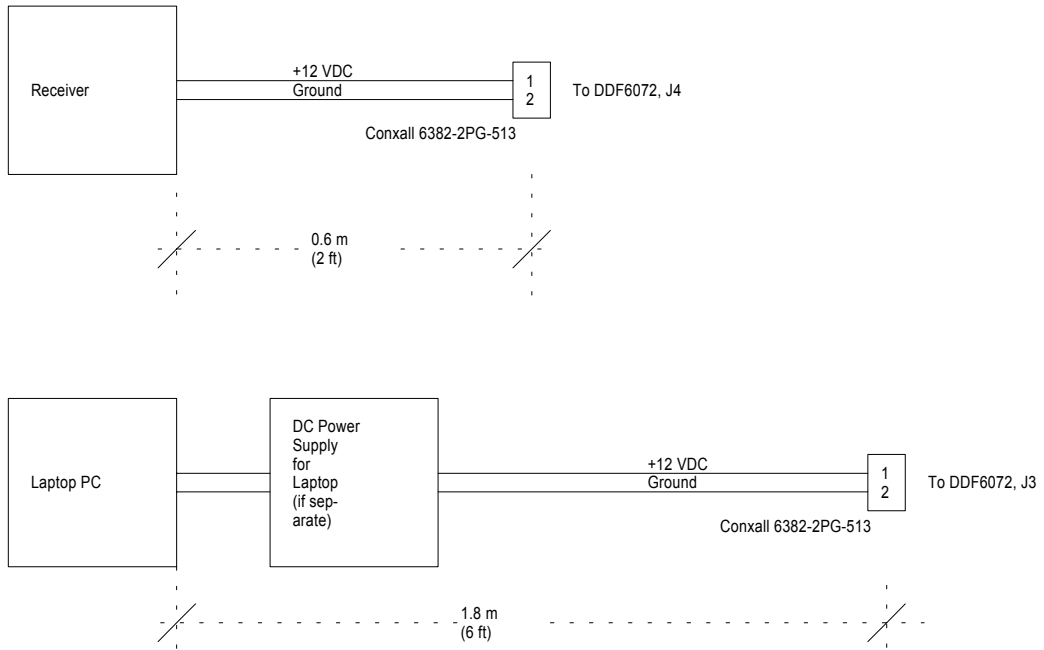

Figure 4-7
Receiver and Laptop Power Cabling

5.0 Operation

5.1 Initialization

During turn-on, the bearing and S-meter displays will momentarily indicate the software version used by the processor. The software version is displayed as X.XX in the bearing window and 1 in the S-meter window.

Parameter values (sweep rate, port communications parameters, etc.) are remembered during power off and restored upon power turn on. It is also possible to restore the factory default values of all parameters by entering from the front panel controls: Sweep rate=0, CAL enabled, BRG=0. The default parameters are listed in Table 6-1. Note, however, that the bearing calibration values will also be returned to the factory default values and a recalibration will be necessary.

5.2 Calibration

The bearing angle and the S-meter display are easily calibrated from the front panel.

Calibrate the bearing display so it reads 0 degrees when receiving a signal from straight ahead. To perform this calibration, use a strong steady signal such as a repeater output, NOAA weather station, etc. Be sure the vehicle is in an area free of reflections with a clear line of sight to the known transmitter. Select the CAL mode by pressing the CAL switch. The CAL light will remain ON. Then press the BRG = 0 switch, and the bearing should read 0 degrees. Repeat this procedure for sweep rates of 300, 600, 1200 and 2400 Hz. Do not try to calibrate the bearing to 0 with the sweep rate set for 0; this is a special command that is used to restore the factory default parameter settings (see above).

The direction of rotation reverses every 0.5 second. This feature allows non-linearities in the receiver to be compensated by averaging consecutive bearing readings. If the number of averages is selected to be 1 the individual bearing data will be displayed, and if the system needs calibration, the readings will alternate between two different values. Be sure to recalibrate the unit if you see this occurring. Normally, you should operate the direction finder with 2 or more averages selected in order to obtain the benefits of the clockwise/counterclockwise rotation.

If the S-meter is not connected to the receiver, or if it has not been calibrated, the S-meter will display a dash. To calibrate the S-meter, the CAL switch must first be enabled, then the SIG=9 switch pressed when a strong signal is present, and the SIG=0 switch when no signal is present.

5.3 Direction Finding in the Continuous Mode (Pulse Mode OFF)

The simulated rotation of the antenna by the direction finder produces a tone in the receiver's audio output, which you will not normally hear because it is filtered out in the direction finder before it is passed to its speaker; you can hear it if you wish by removing the audio plug from the receiver's external speaker output.

The DF measures the magnitude and the phase of the tone every 10 milliseconds and calculates bearing angle from this data every second.

The DF software determines whether a signal is present by examining the statistics of the sampled data. If the average amplitude of the tone exceeds the variation of the data about the average, then it is concluded that a signal is present and the bearing is displayed. This scheme makes the system independent of the receiver's volume control setting, so the volume may be set at any comfortable level. In addition, the receiver's squelch can be set normally or it can be opened so that the receiver is unquieted. If no signal is present, the DF will detect this condition from the lack of a stable sweep tone, and will not update the display.

The sweep rate can be adjusted set to 300, 600, 1200 or 2400 Hz from the front panel. Maximum sensitivity and stability is obtained at the higher sweep rates, but there may be occasions when a lower sweep rate is desired. For example, if the signal itself contains a 1200 Hz tone, you would want to use a sweep rate other than 1200 Hz. A sweep rate of 2400 Hz results in a peak deviation that exceeds the 15 KHz bandwidth of most narrow band fm receivers. You will notice distortion of the transmitted audio with this sweep rate when receiving with a narrow band fm receiver. This sweep rate is useful however if you need to DF a wide band fm signal for which you must, of course, use a wide-band (150 KHz bandwidth) receiver.

The front panel display updates twice every second. Bearings are retained for 10 seconds, and then the display is blanked. To distinguish an updated bearing from a retained bearing of the same value, the decimal point on the display alternates ON and OFF whenever the display is updated.

If the number of averages is set to 1, then the bearing display is that calculated by the software during the preceding 0.5-second interval. The processor can also calculate a moving average of the preceding bearings. This will cause the bearing angle to be more stable, but it will also be less responsive to actual changes in the bearing. As discussed in Section 5.2, the antenna sweep direction is reversed every 0.5 seconds to permit reduction of errors due to non-linearities in the receiver. While the direction finder can be used with the number of averages set to 1, it is usually best to set it to 2 or higher to obtain the benefits of averaging opposite direction sweeps.

The preamplifiers used in the direction finder antenna electronics have a gain of about 12 dB and a noise figure of about 3.6 dB. These are very broadband devices which can generate intermod products if very strong input signals are present. Depending on the location of the antenna and the frequency band being used, you may notice an increase in the noise level of the receiver which is due to mixing of two strong input signals (for example, a broadcast fm station and a television video or audio signal). The intermod can be reduced by enabling the attenuator switch on the direction finder which applies 20 dB attenuation between each antenna element and its associated preamplifier.

5.4 Direction Finding in the Pulse Mode

The pulse mode logic has been optimized for a pulse duration of 150 milliseconds and a period of 0.5 second. This type of pulse is frequently generated by the type of transmitter or beacon used for target tracking. It is possible to change the pulse duration and period to other commonly used values; see Section 6.4. Enter the pulse mode by pressing the Pulse Mode switch.

As in the continuous mode, the processor again samples the sweep frequency data every 10 milliseconds and calculates the bearing angle each 0.5 second. To determine whether a signal (pulse) was present during the 0.5-second interval, a correlation calculation is made. The amplitude of the tone is calculated over every 150 millisecond subinterval and the subinterval with the highest value is noted. The amplitude is then calculated over the 350 millisecond interval that does not include the selected 150 milliseconds. The two averages are then compared, and if a criterion is exceeded, it is concluded that a pulse occurred during the display interval. The bearing angle is then calculated from the phase of the tone data in the selected 150 millisecond interval.

This method permits the receiver volume to be adjusted without affecting the bearing, and the receiver squelch can be set normally or left open. Maximum sensitivity is obtained with the receiver unsquelched.

Consecutive bearings may be averaged. The number of samples averaged may be selected to be 1, 2, 5, 10 or 20. Unlike the continuous mode, the antenna sweep direction is not reversed every 2 second.

5.5 Homing

When the direction finder is used to home on a signal source, the following guidelines should be followed.

Take an assistant with you. Don't try to read the display and drive at the same time.

Try to keep out of high multipath areas (buildings, etc.) as long as possible.

Avoid strong interfering signal locations (broadcast stations, etc.)

Keep moving when the signal is present. Multipath averages out spatially (not temporally).

5.6 Auto Triangulation

See the manual that accompanies the Auto Track Software program for directions on operating the DDF6100 to Auto Triangulate. It is possible to calibrate the direction finder and to change operating parameters (sweep rate, etc.) from the laptop computer using this program. Bear in mind, that when used in this mode, the DDF6100 will be calibrated to display bearing relative to North, so looking at the front panel LEDs can be confusing. Another difference in operation between the homing mode and auto triangulation operation is that your strategy for driving will be different. With homing, you generally drive

in as straight a line as possible toward the emitter, while when auto triangulating, you will generally circle or spiral around the emitter.

6.0 Serial Interfaces

6.1 Introduction

Serial communication ports are provided at five rear panel connectors. Port #0 is connected to J1, port #1 to J4, port #2 to J2, port #3 to J10, and port #4 to J11.

The PC used to control the DDF6100 must be connected to port #0 (J1). If channel control from the PC is desired, the receiver must have a CIV interface, and it must be connected to port #1 (J4). The GPS and/or compass should be connected to ports #2,3 or 4 (J2, J10 or J11).

6.2 Hardware Interfaces

Figure 6-1 shows the wiring of serial interface connectors J1, J2, J4, J10 and J11.

6.2.1 Connector J1 (port #0)

Connector J1 is a DE9S wired as Data Control Equipment (DCE). All voltage levels and impedances are RS232. J1 may be connected to the serial port of a PC using a straight through DE9P to DE9S cable.

RTS, CTS, DSR, DTR, CD and RD are not connected.

The port #0 baud rate is fixed at 9600 with 8 data bits, no parity and 1 stop bits.

6.2.2 Connectors J2, J10 and J11 (ports #2, 3 and 4)

These connectors are DE9P wired as Data Terminal Equipment (DTE). Transmit and receive voltage levels and impedances are RS232. They may be connected to the GPS serial interface using a straight through DE9P to DE9S cable.

RTS, CTS, DSR, DTR, CD and RD are not connected.

The default baud rate is 4800 with 8 data bits, no parity and 1 stop bit. The baud rate may be set to 1200, 2400, 4800 or 9600, parity to none, even or odd, the number of data bits to 7 or 8, and the stop bit length to 1 or 2 by serial commands.

6.2.3 Connector J4 (port #1)

Connector J4 is a 3.5 mm jack connected for CIV bus operation. Transmit and receive voltage levels are TTL. The output is pulled up to +5 VDC through a 5.1 K resistor.

The default baud rate is 1200 with 8 data bits, no parity and 1 stop bit. The baud rate may be set to 1200, 2400, 4800 or 9600, parity to none, even or odd, the number of data bits to 7 or 8, and the stop bit length to 1 or 2 by serial commands.

6.3 Message Protocol

6.3.1 Direction Finder Messages

Serial commands to the direction finder are in ASCII format. These messages begin with a \$ character and end with a carriage return <CR>. Line feeds <LF> are ignored. All direction finder commands are listed in Table 6-1. A typical command requesting the bearing angle (command #0) is:

\$ 0 <CR> or in hex: 24 30 13

Responses from the direction finder are discussed below.

6.3.1.1 Bearing Message

The response to commands 0 or 980 (DF data request) is the NMEA 0183 message \$DFBRG,XXX,Y,Z*HH<CR><LF>. In this message, XXX is the bearing angle, Y is the signal strength, and Z is a parameter indicating the validity of the returned bearing data. HH is the check sum. This is given by two ASCII digits which is the 8-bit exclusive OR of all characters between the \$ and * characters.

In the DDF6100, bearing and signal strength are computed on a 0.5 second interval. The sampling interval of the serial readout (command 0) may be shorter or longer than 0.5 second, and the validity flag Z provides a method to synchronize the two clock cycles. After the data is read out serially, the validity flag Z is set to zero, so if a second readout is made before the bearing is updated, the validity flag Z is returned equal to 0. After the data is updated within the DDF6100, the validity flag is set to 1 if the data meets the signal to noise requirement, and it is set to 2 if it does not.

It is recommended that the PC which is requesting the bearing data do so at a rate of approximately twice per second, and that it ignore any returned data that does not have a validity Z equal to 1.

Command 0 causes the bearing message to be sent once while command 980 causes the same message to be output automatically from the direction finder whenever the bearing is updated. This is the default mode for the DDF6100, and it is disabled by command number 981.

6.3.1.2 Hardware Message

The response to command 982 (identify hardware) is the NMEA 0183 message \$DFHW,XXXXX*HH<CR><LF>. In this message, XXXXX is the hardware model with revision letter; for example, 6100-. HH is the check sum. This is given by two ASCII digits which is the 8-bit exclusive OR of all characters between the \$ and * characters.

6.3.1.3 Software Message

The response to command 983 (identify software) is the NMEA 0183 message \$DFSW,X.XX*HH<CR><LF>. In this message, X.XX is the software revision; for example, 2.07. HH is the check sum. This is given by two ASCII digits which is the 8-bit exclusive OR of all characters between the \$ and * characters.

6.3.1.4 Panel Message

The response to command 997 (send panel message) is the NMEA 0183 message \$DFPNL,X,Y,Z*HH<CR><LF>. In this message, X, Y and Z may be decoded as given in the following tables. HH is the check sum. This is given by two ASCII digits which is the 8-bit exclusive OR of all characters between the \$ and * characters.

Number of averages	X
1	0
2	1
5	2
10	3
20	4

Sweep rate	Y
0	0
300	1
600	2
1200	3
2400	4

Cal	Pulse	Atten	Dim	Z
Off	Off	Off	Dim	0
Off	Off	Off	Bright	1
		Etc.		
On	On	On	Dim	E
On	On	On	Bright	F

6.3.2 Receiver Messages

Messages to and from the receiver are in CIV format. This format is:

PR PR RA TA CN SC DT SF

where PR is the preamble (hex FE), RA is the receive address, TA is the transmitter address, CN is the command number, SC is the (optional) subcommand, DT is the data (and may be several characters in length), and SF is the message suffix (hex FD). The maximum length of a CIV message (including prefixes and suffix) is 80 characters.

Received messages are buffered, and if a jamming character (hex FC) is detected anywhere within the message, the message is ignored. Also, the received message must begin with at least two prefix characters or it will be ignored.

The Auto Track software program uses the ICOM receiver frequency command message and looks for the ICOM CIV acknowledgment message.

Refer to the ICOM CIV reference manual for further details on the structure of CIV commands for their receivers.

6.3.3 GPS Messages

The GPS receiver must provide two messages. These are the NMEA 0183 GGA and VTG messages. These are to be output at a rate of once per second or slower.

6.3.4 Compass Messages

If a compass is used, it must provide the NMEA HDM message at a rate of approximately once per second.

6.4 Multiplexing and Control Characters

Data between the PC and the DDF6100 is transferred in packets which are multiplexed between the direction finder itself and the four serial port (#1-4). These packets contain up to 15 characters in length, and are of the form:

<Ax><n><D1><D2>.....<Dn>

where <Ax> is the port address that the message is coming from or going to:

Ax (hexadecimal)	Port Number
F0	0 (DDF6100)
F1	1 (J4)
F2	2 (J2)
F3	3 (J10)
F4	4 (J11)

<n> is the number of bytes in the packet and is a number between 1 and 15 (hex 1 through F).

<D1>, <D2>, etc. are the actual data bytes in the message. As an example, a typical bearing message from the DDF6100 to the PC would be encoded as follows:

\$DFBRG,186,9,1*4E<CR><LF>

This message has a total of 19 characters. It will be sent in two packets.

F0	0F	24	44	46	42	52	47	2C	31	38	36	2C	39	2C	31	2A
		\$	D	F	B	R	G	,	1	8	6	,	9	,	1	*

F0	04	34	45	13	10
		4	E	CR	LF

Table 6-1
DDF6100C Serial Command List

Command Number	Description of Command. Default values shown in bold .
0	request bearing data
1	number of averages = 1
2	number of averages = 2
3	number of averages = 5
4	number of averages = 10
5	number of averages = 20
6	sweep rate = 0
7	sweep rate = 300
8	sweep rate = 600
9	sweep rate = 1200
10	sweep rate = 2400
11	attenuator = ON
12	attenuator = OFF
13	pulse mode = ON
14	pulse mode = OFF
15	cal flag = ON
16	cal flag = OFF
17	cal bearing to zero (requires cal flag ON)
18	cal S-meter to zero (requires cal flag ON)
19	cal S-meter to nine (requires cal flag ON)
20	intensity = BRIGHT
21	intensity = DIM
22	port1 baud rate = 1200
23	port1 baud rate = 2400
24	port1 baud rate = 4800
25	port1 baud rate = 9600

26	port1 data bits = 7
27	port1 data bits = 8
28	port1 stop bits = 1
29	port1 stop bits = 2
30	port1 parity = NONE
31	port1 parity = EVEN
32	port1 parity = ODD
33 through 239	Calibrate the bearing to the value given by the command number - 33. For example, command 33 calibrates the bearing to 0 degree.
240 through 255	These commands are not allowed because of conflicts with the CIV control characters.
256 through 408	Calibrate the bearing to the value given by the command number - 49. For example, command 256 calibrates the bearing to 207 degrees.
409 through 495	Not defined.
496 through 511	These commands are not allowed because of conflicts with the CIV control characters.
512 through 670	Not defined.
671 through 721	Not defined.
722	port2 baud rate = 1200
723	port2 baud rate = 2400
724	port2 baud rate = 4800
725	port2 baud rate = 9600
726	port2 data bits = 7
727	port2 data bits = 8
728	port2 stop bits = 1
729	port2 stop bits = 2
730	port2 parity = NONE
731	port2 parity = EVEN
732	port2 parity = ODD
733 through 751	Not defined.
752 through 767	These commands are not allowed because of conflicts with the CIV control characters.

768 through 821	Not defined.
822	port3 baud rate = 1200
823	port3 baud rate = 2400
824	port3 baud rate = 4800
825	port3 baud rate = 9600
826	port3 data bits = 7
827	port3 data bits = 8
828	port3 stop bits = 1
829	port3 stop bits = 2
830	port3 parity = NONE
831	port3 parity = EVEN
832	port3 parity = ODD
833 through 899	Not defined.
900 through 920	Set the signal to noise ratio threshold used in the continuous mode to the value given by the (command number - 900)/10. For example, command 912 sets the threshold to 1.2
921	Not defined.
922	port4 baud rate = 1200
923	port4 baud rate = 2400
924	port4 baud rate = 4800
925	port4 baud rate = 9600
926	port4 data bits = 7
927	port4 data bits = 8
928	port4 stop bits = 1
929	port4 stop bits = 2
930	port4 parity = NONE
931	port4 parity = EVEN
932	port4 parity = ODD
933 through 976	Not defined.
977	Enable sync pulse mode.

978	Disable sync pulse mode.
979	Not defined.
980	Output bearing data automatically.
981	Turn off automatic data output.
982	Identify hardware.
983	Identify software.
984	Enable self test input (disconnects receiver input).
985	Disable self test input (connects receiver input).
986	Enable front panel switches.
987	Disable front panel switches.
988	Select VHF antenna.
989	Select UHF antenna.
990	Set time period for display update and pulse rep rate to 0.5 seconds.
991	Set time period for display update and pulse rep rate to 1.0 seconds.
992	Set time period for display update and pulse rep rate to 1.5 seconds.
993	Set pulse on-time to 150 milliseconds for correlator.
994	Set pulse on-time to 180 milliseconds for correlator.
995	Set pulse on-time to 200 milliseconds for correlator.
996	Test LEDs.
997	Send panel message.
998	Set factory defaults.
999	Reset processor.

7.0 Test Software

The DOS utility program, SERCMD.EXE is included to permit testing of the serial interfaces. This program decodes and displays the packetized messages from the five sources (the DDF6100 itself and the four ports #1-4), and it provides a means for sending test messages to each of these ports from the PC.

The program displays the data as it is received and de-packetized from the direction finder (port #0) and the four external ports (#1 through 4) in five scrolling windows which comprise most of the screen.

If the DDF6100 is in its default state and displaying a bearing, the bearing data will be automatically sent to the PC and displayed in the port #0 response window at the very top of the screen.

At the bottom of the screen are two command lines. The first contains a fixed CIV message which changes the frequency of an ICOM R7000 receiver to 162.550 MHZ. Pressing the F1 key will send this message to J4 (port #1). If an R7000 receiver is connected to this port and properly programmed for CIV address, baud rate, etc., it will respond with the ICOM acknowledgment message which will be displayed in the port #1 response window.

The second command line permits entry of any ASCII keyboard characters, and pressing F2, F3 or F4 sends this message to port #2, #3 or #4 respectively. Pressing F5 sends the message to DF port #0. Any response from these ports will be displayed in the corresponding window.

Press <ESC> to quit the program.

8.0 Servicing

8.1 Schematics

A complete set of schematics is provided at the end of this section as an aid to troubleshooting and to clarify interfaces. Because the DDF6100 is a microprocessor based system that uses high density electronic components, it is recommended that the unit be returned to the factory for repair. The only exception is for upgrading of the program EPROM which is described below.

The circuitry used in the DDF6100 is susceptible to electrostatic discharge. Observe proper ESD precautions when servicing the unit.

Overseas customers should refer to the relevant Doppler Distributor.

8.2 EPROM Replacement

Remove the top cover by removing the (23) black 4-40 screws on the top, sides and back of the unit. Tip the top cover up and disconnect the speaker leads so the cover can be removed completely.

Replace the EPROM U123 using proper IC removal and insertion tools and observe electrostatic discharge precautions.

Reconnect the speaker leads and replace the top cover using the black 4-40 screws.

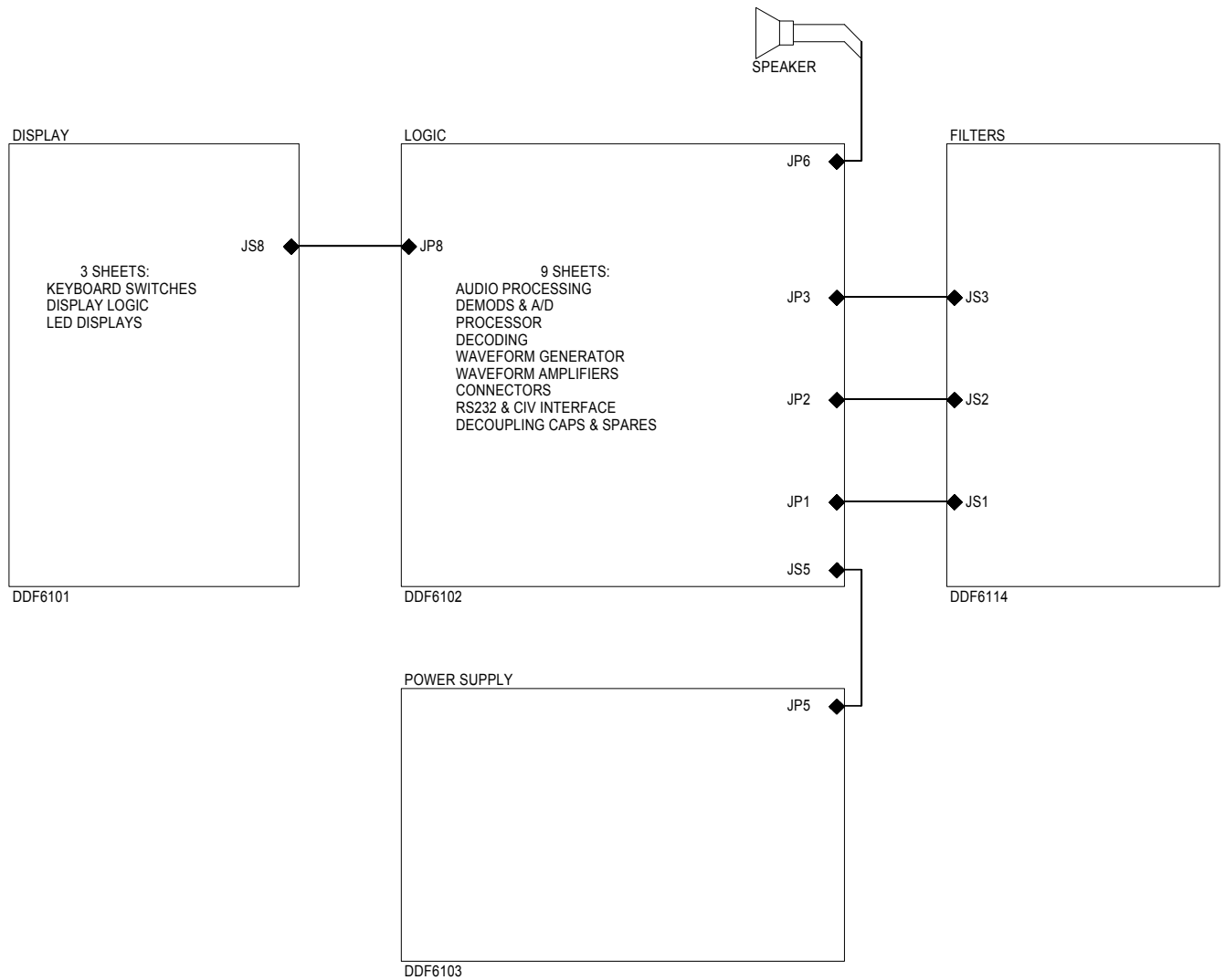

DDF6100 Display Processor Schematics

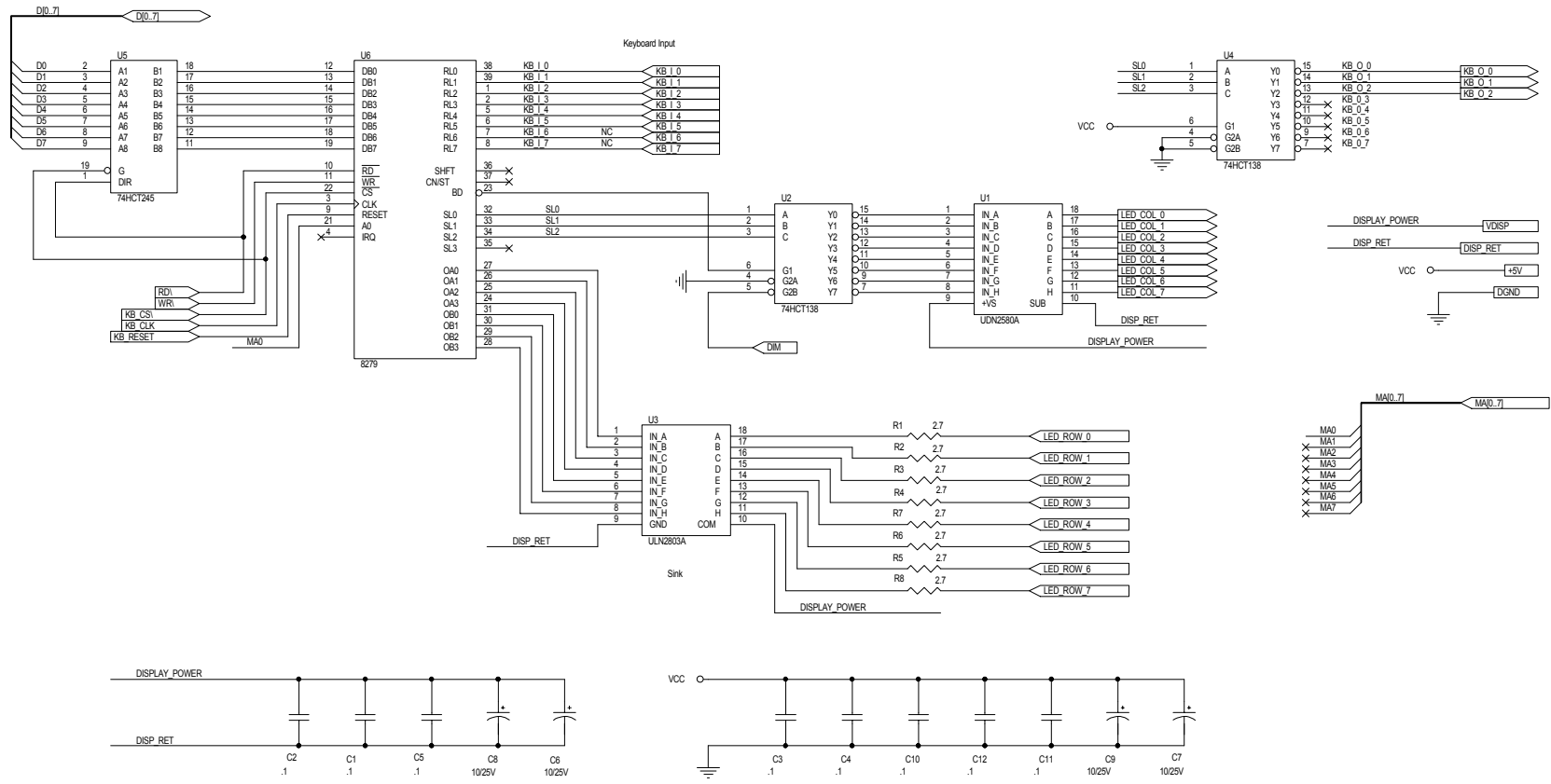

DDF6101 Display Logic

Keyboard Inputs

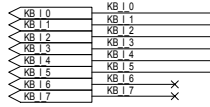

Keyboard Drives

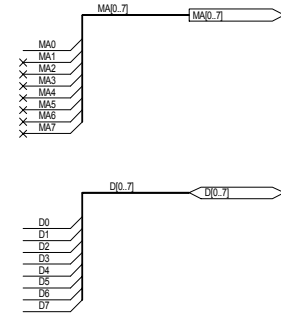
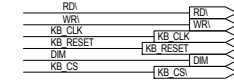
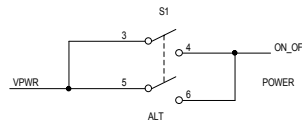
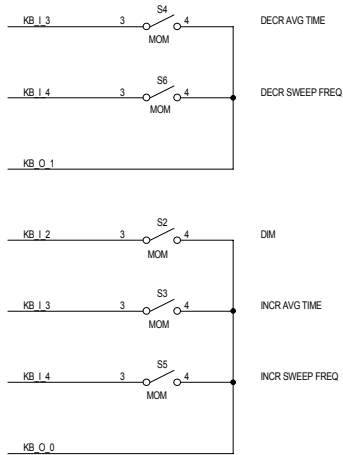
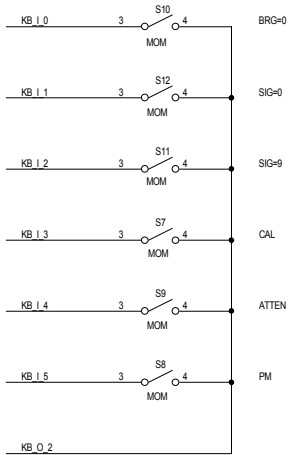
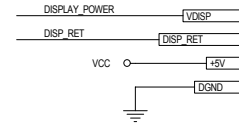
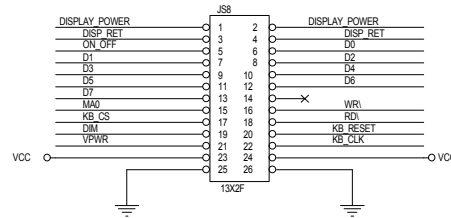

DDF6101 Keyboard Switches

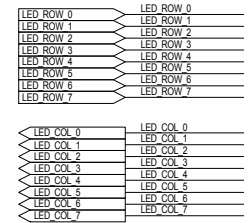
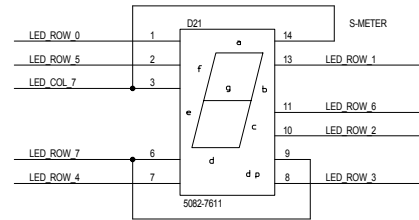
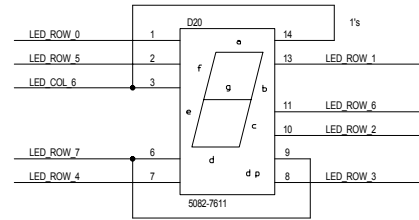
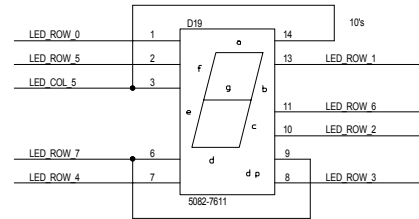
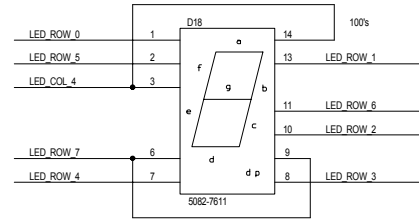
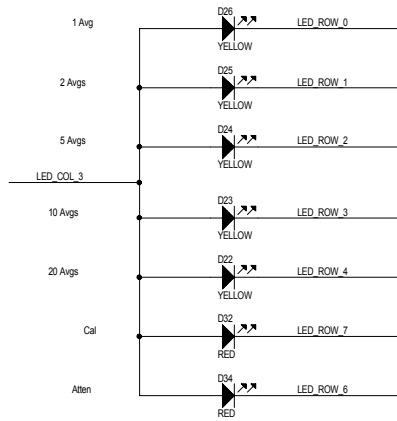
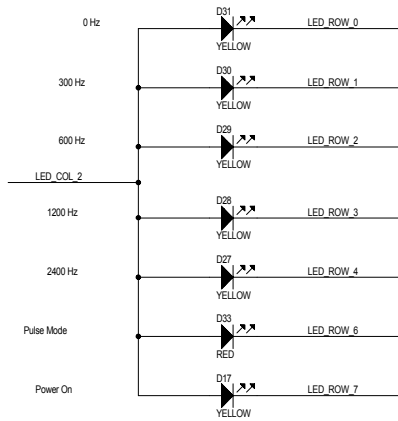
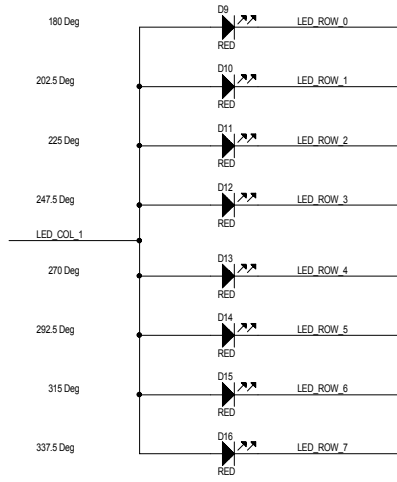
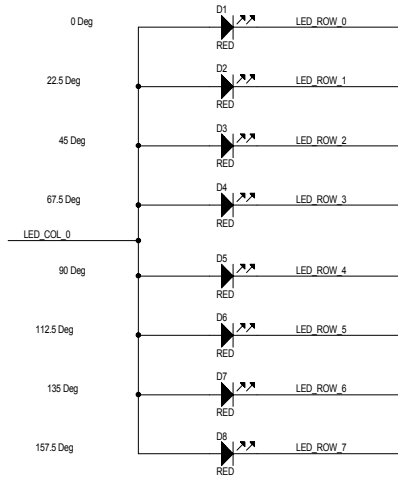

DDF6101 LED Displays

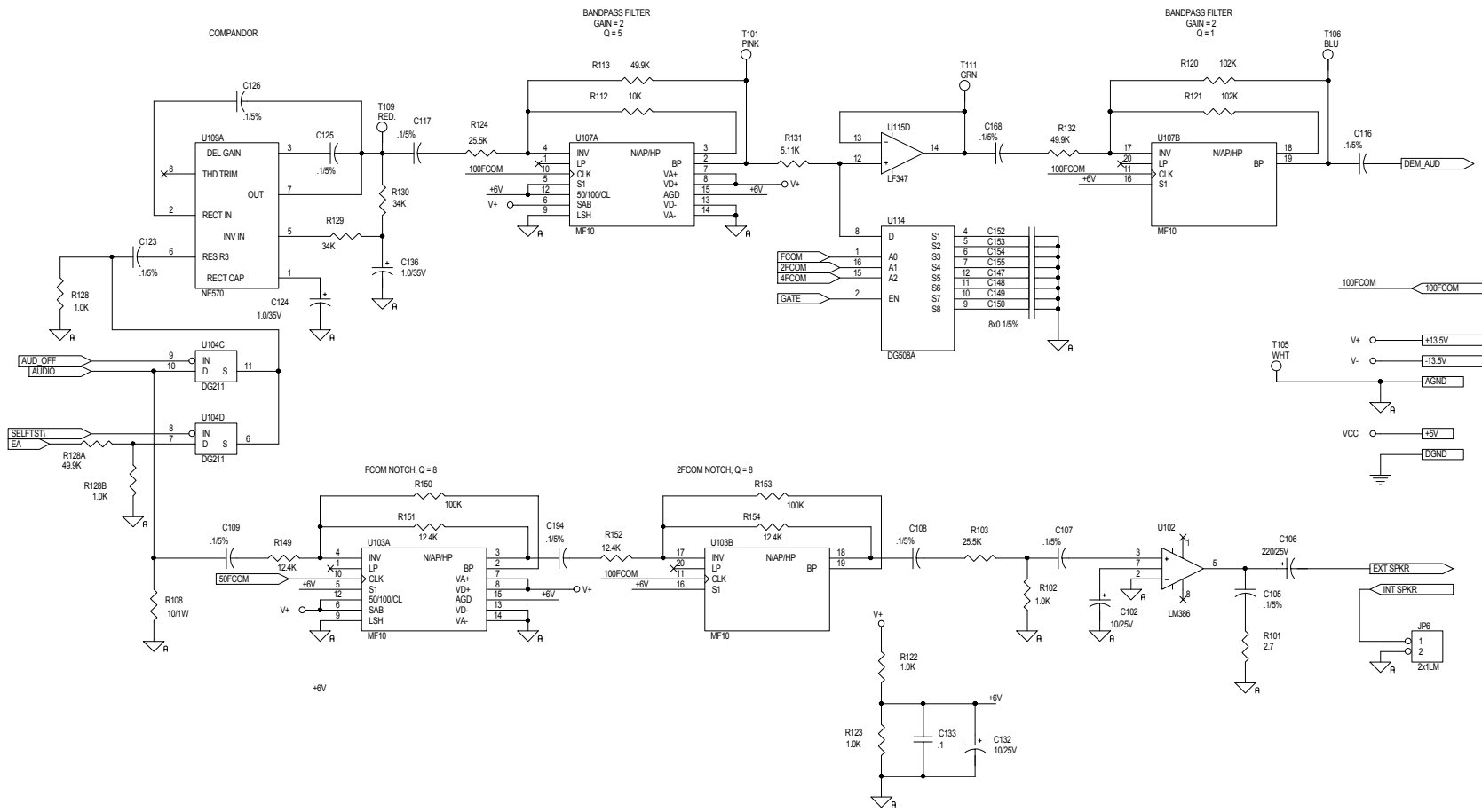

DDF6102 Audio Processing

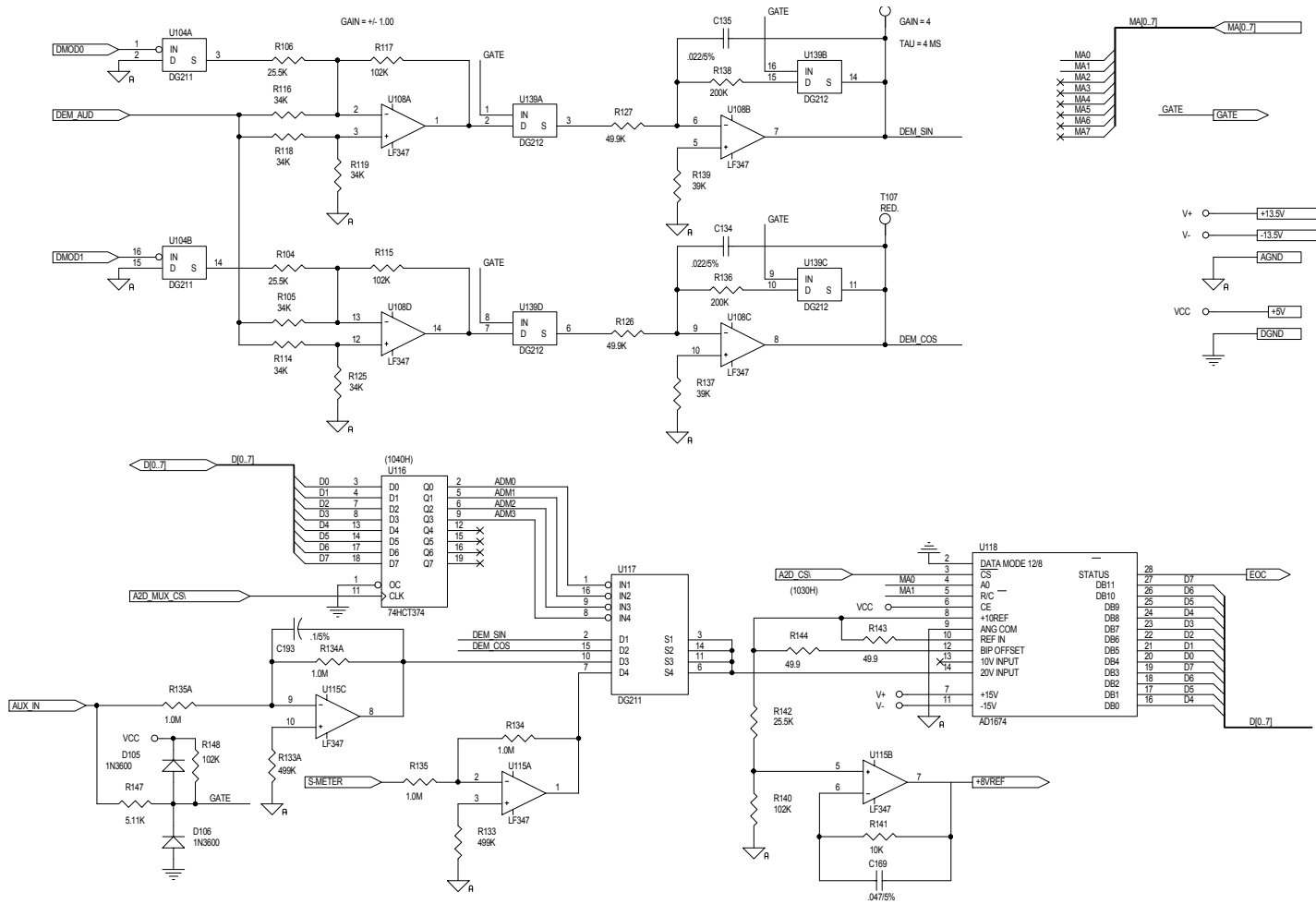

DDF6102 Demods & A/D

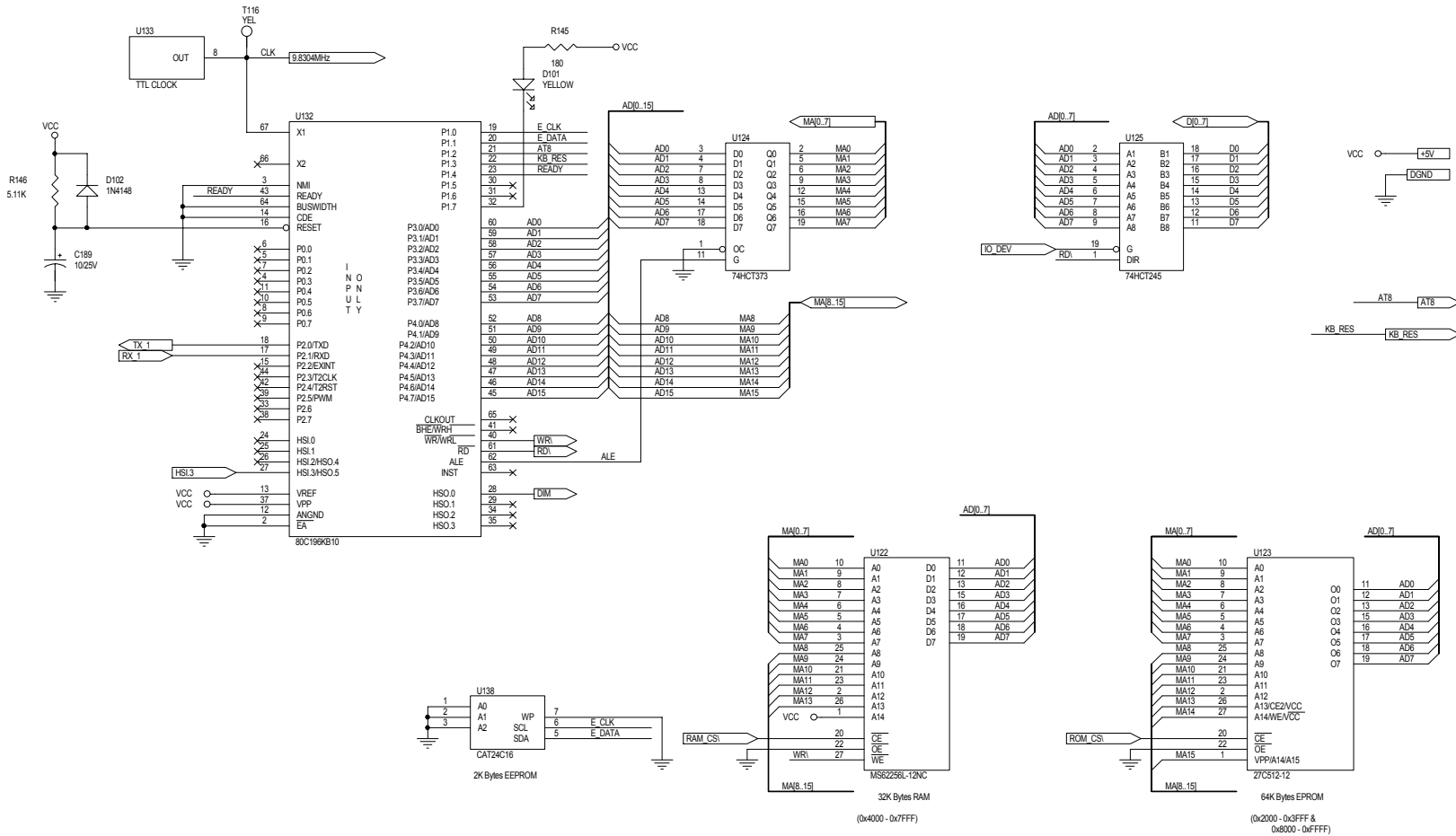

DDF6102 Processor

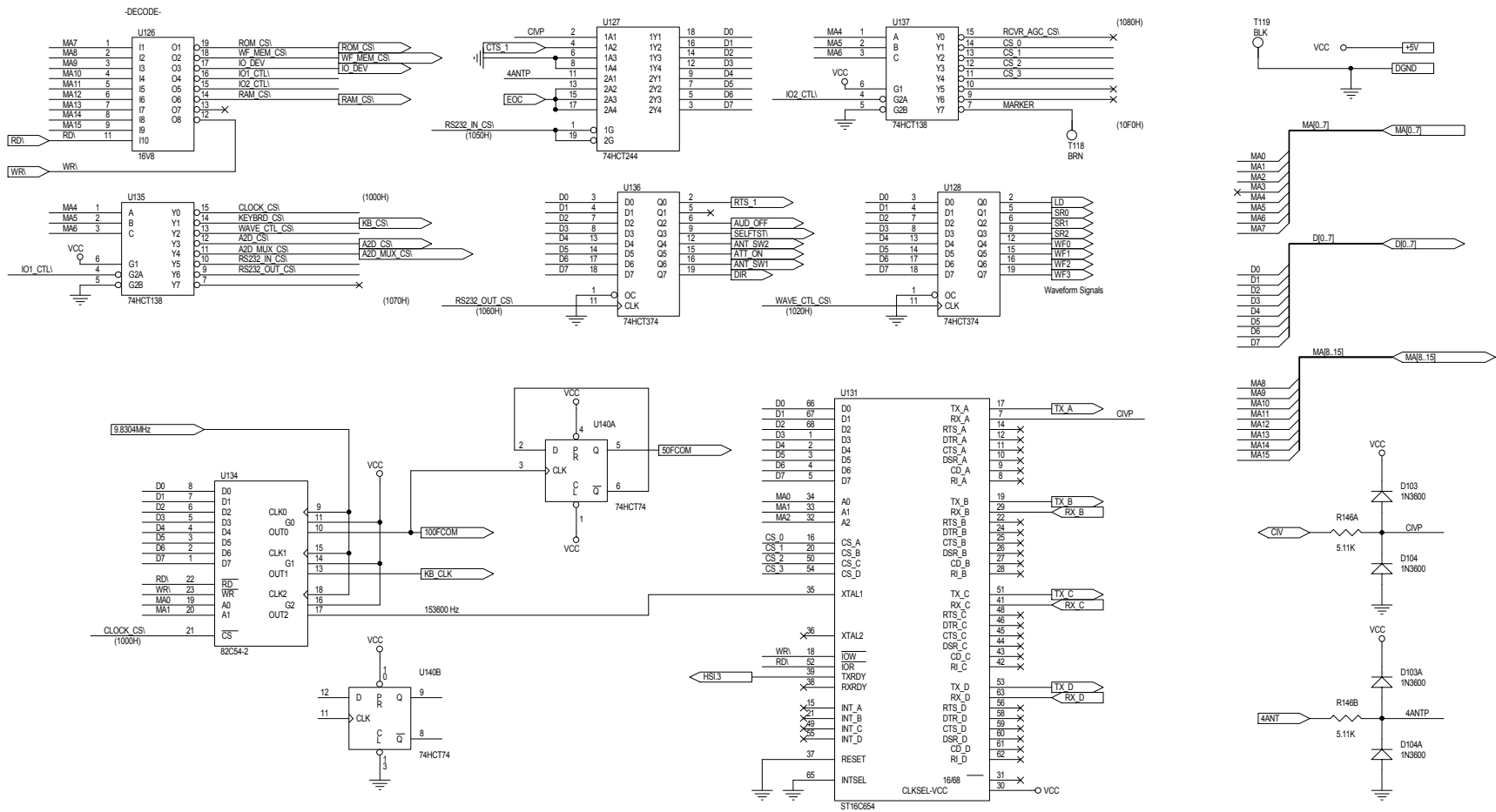

DDF6102 Decoding

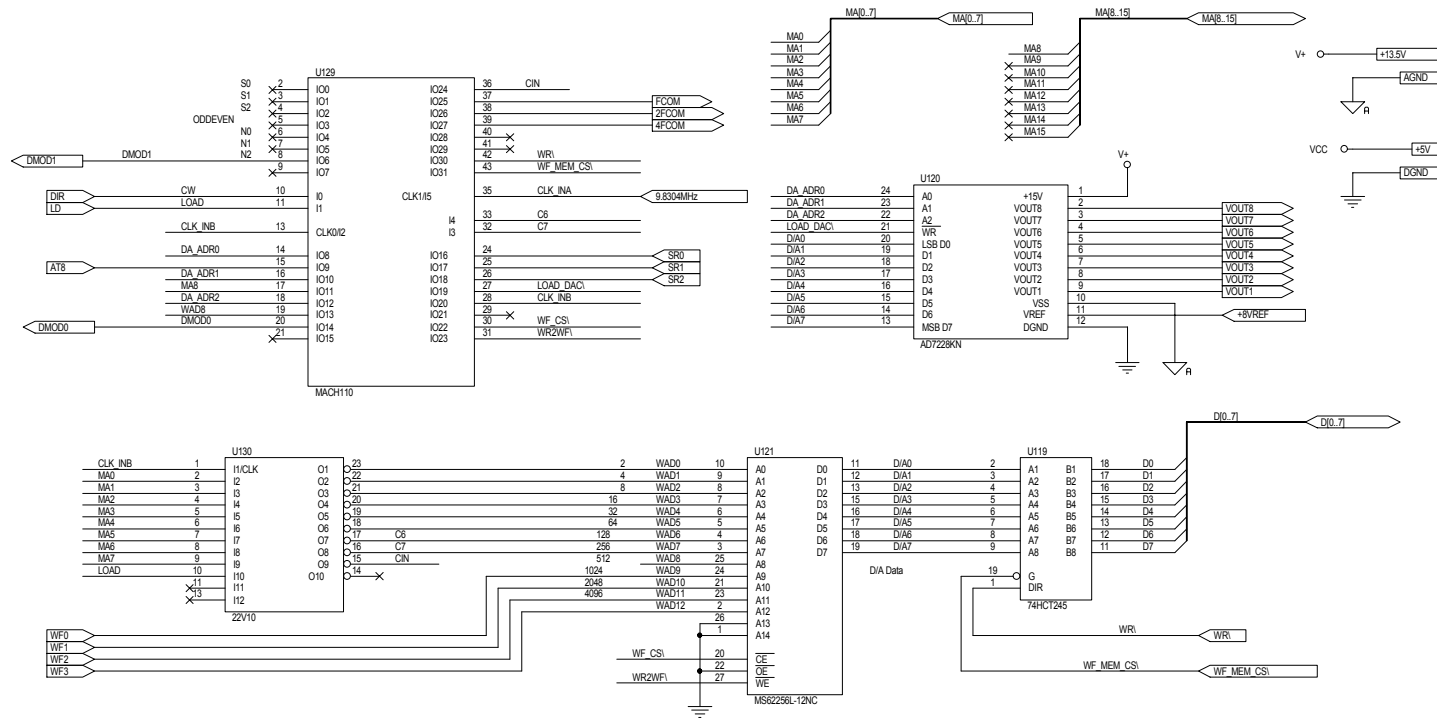

DDF6102 Waveform Generator

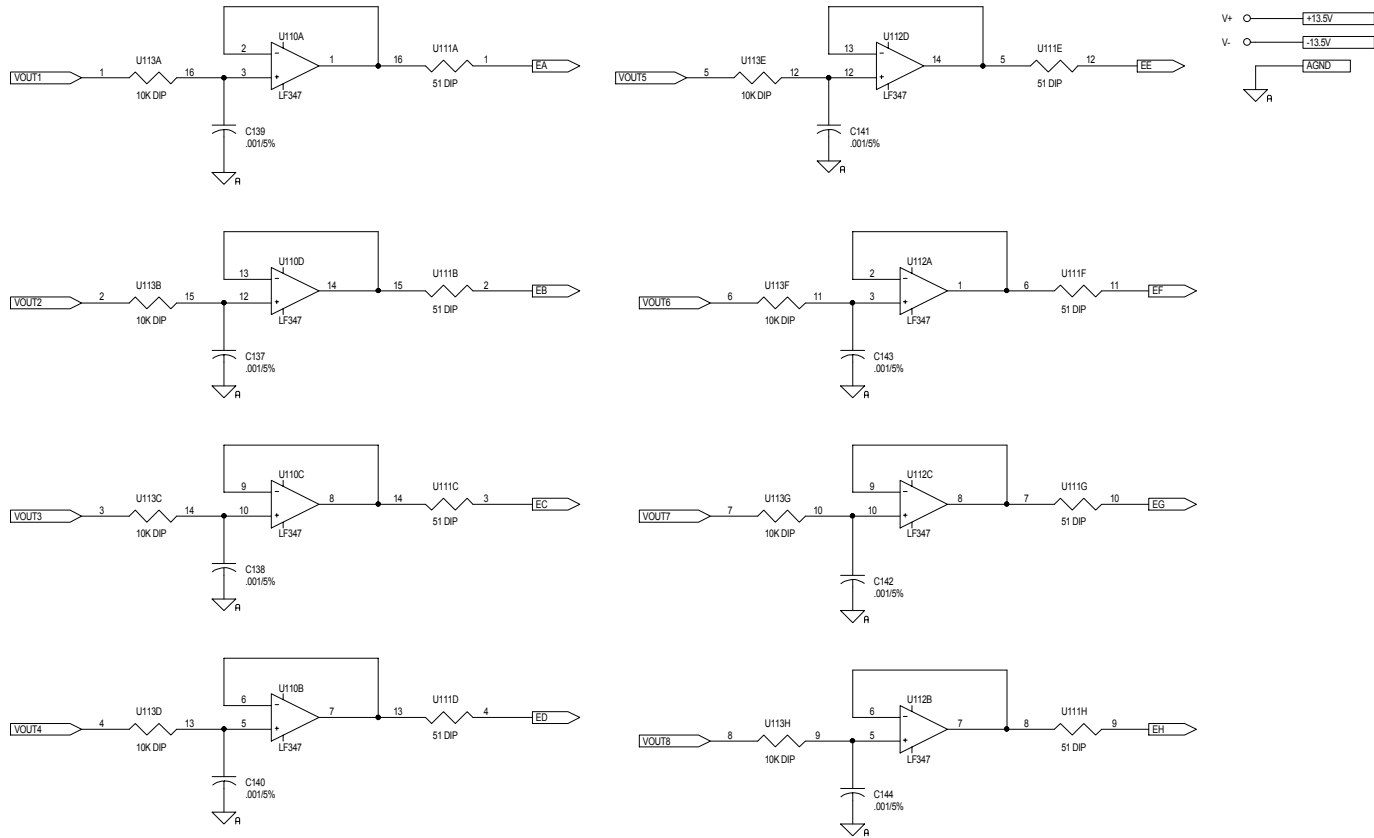

DDF6102 Waveform Amplifiers

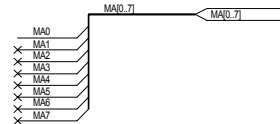
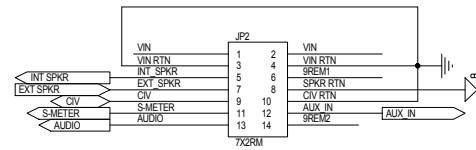
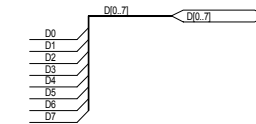
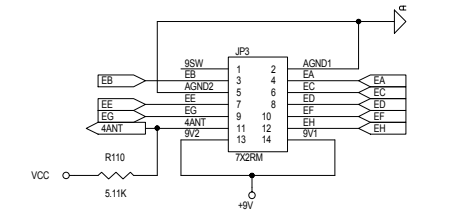
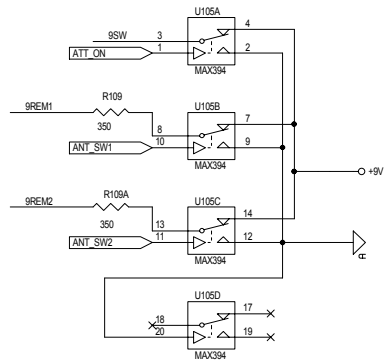
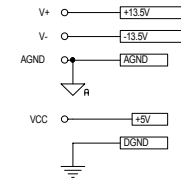
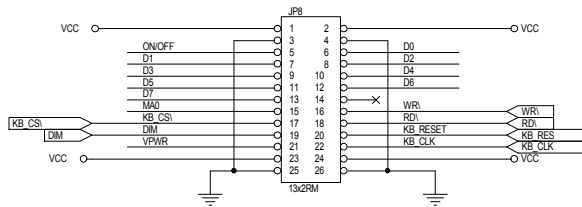
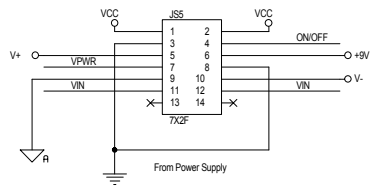

DDF6102 Connectors

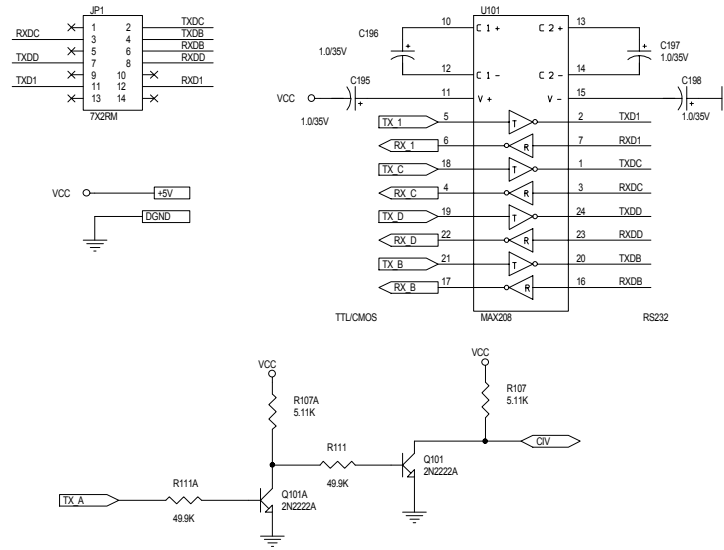

DDF6102 Serial Interfaces

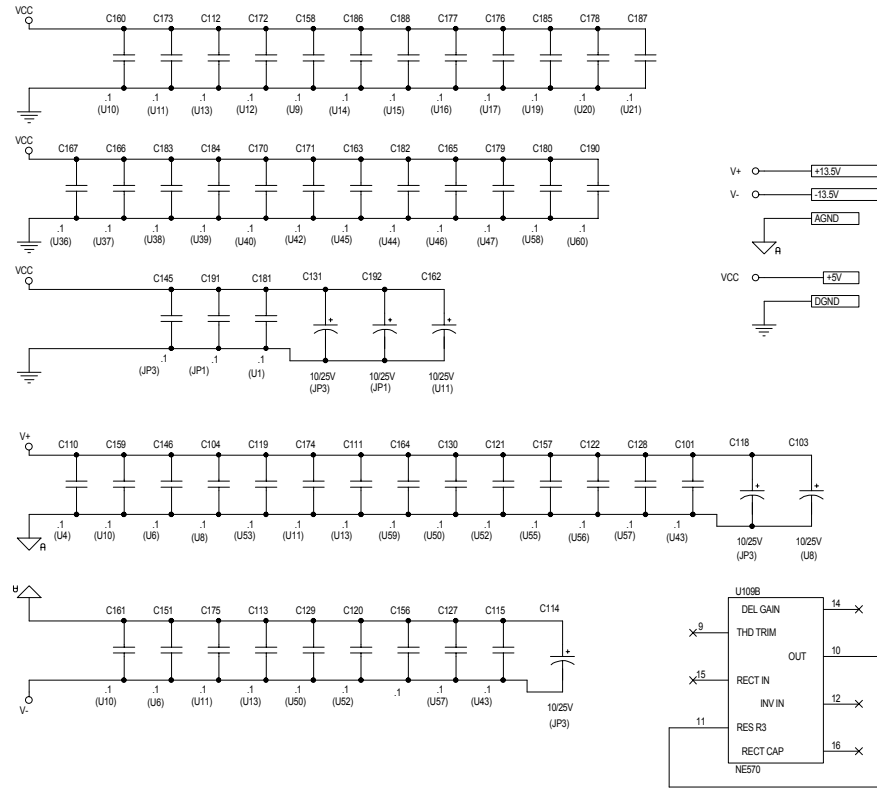

DDF6102 Decoupling Capacitors

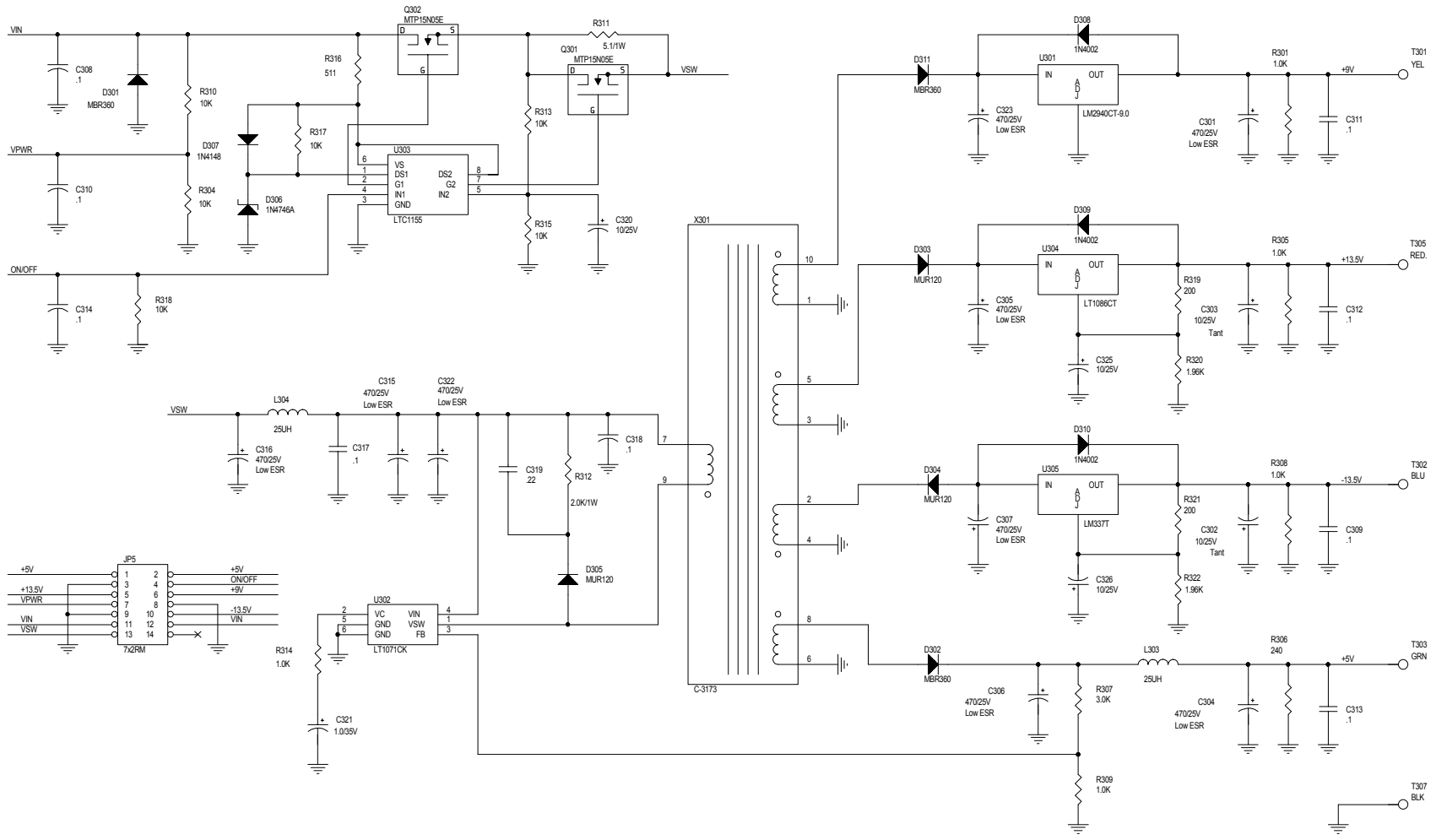

DDF6103 Power Supply

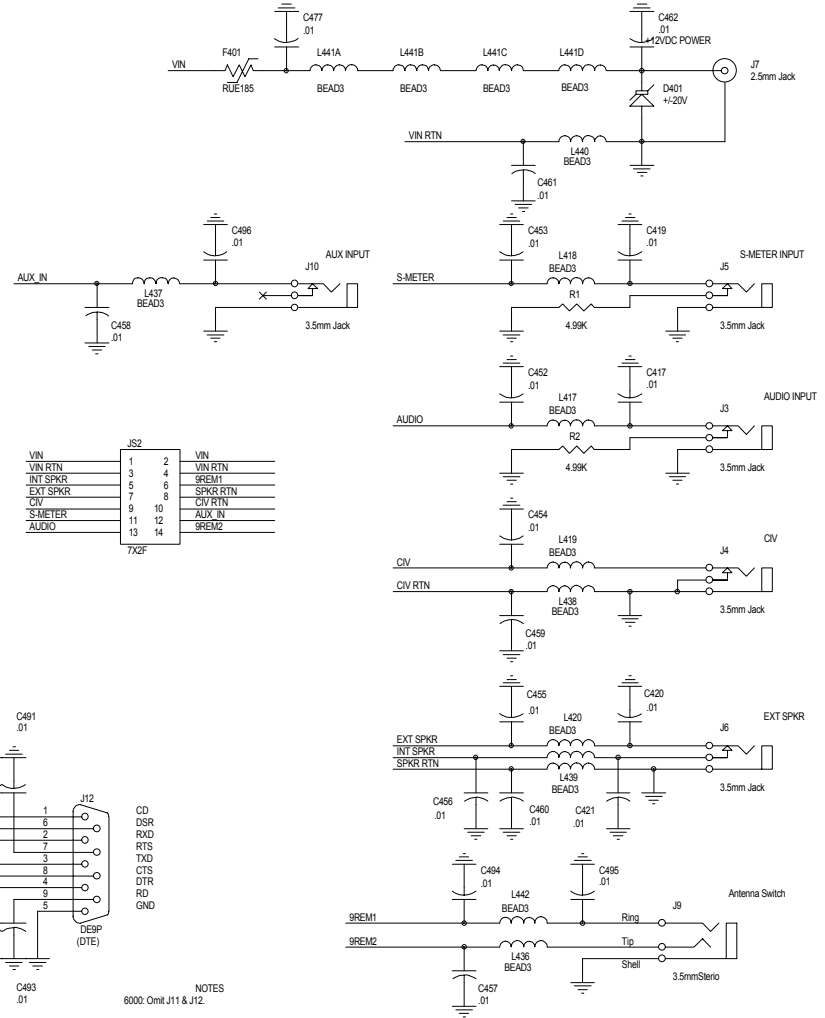
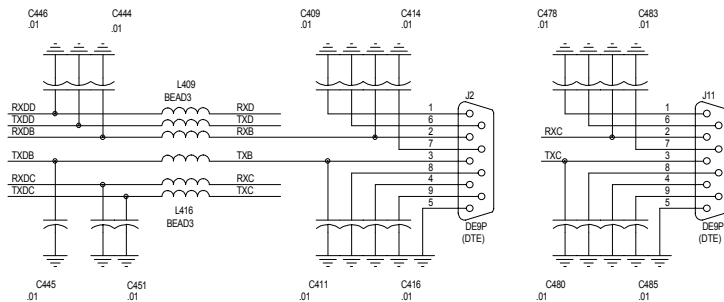
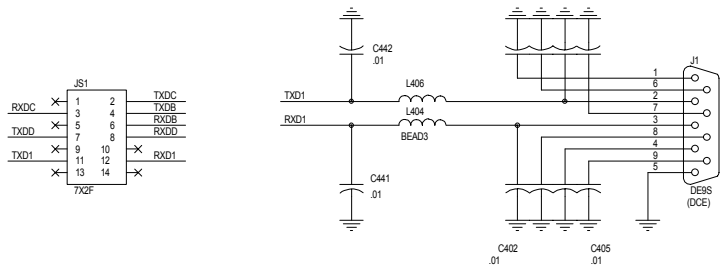
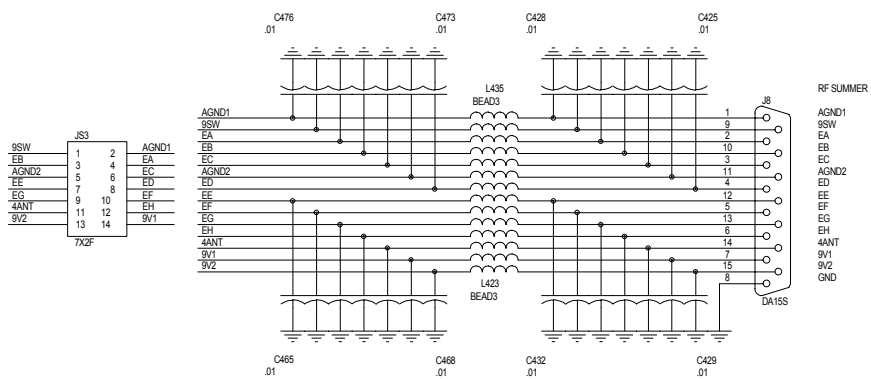

NOTES
6000 Omit J11 & J12.

DDF6114 EMC Filters & Connectors

ANTENNAS DDF606X

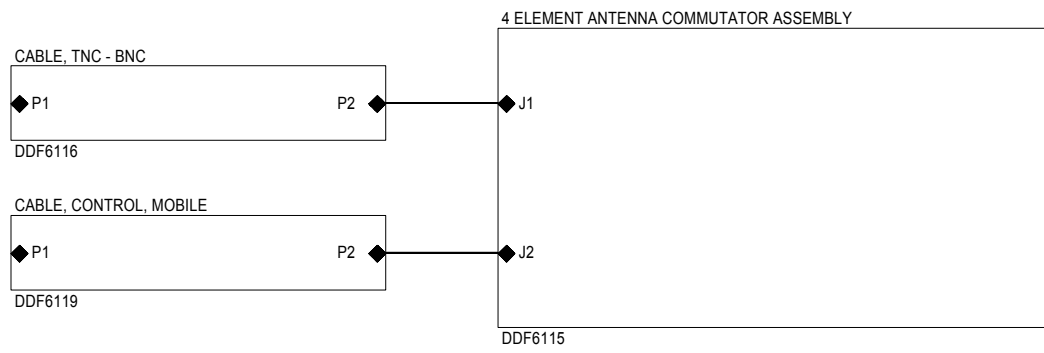

DDF606X
Antenna Schematics

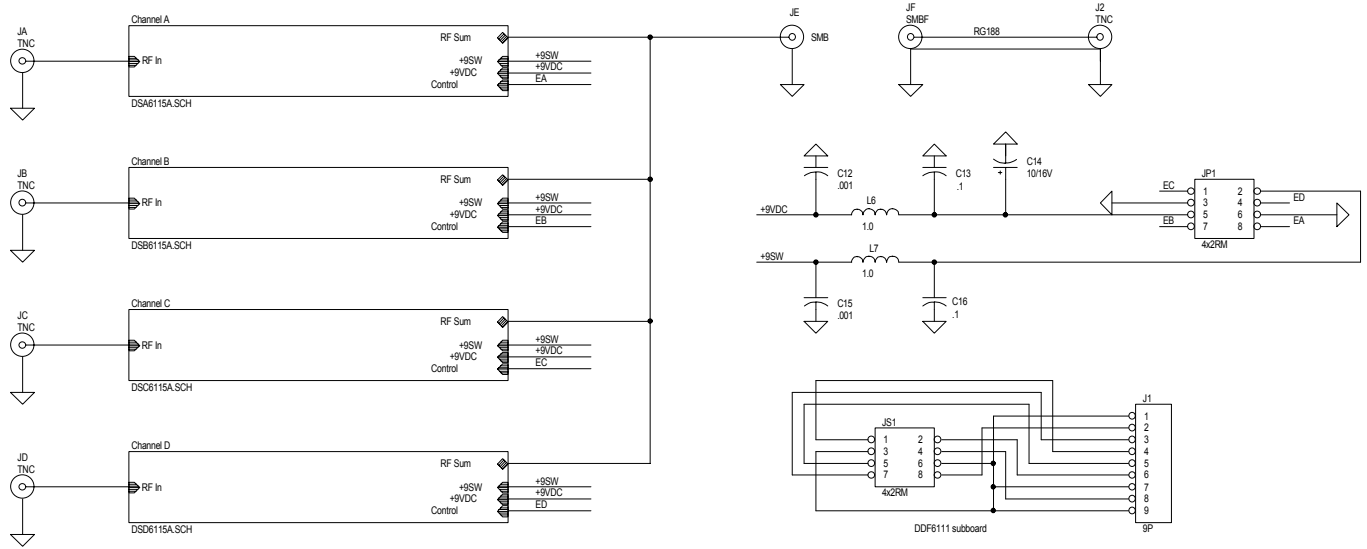

DDF6115
4-Element Commutator Assembly

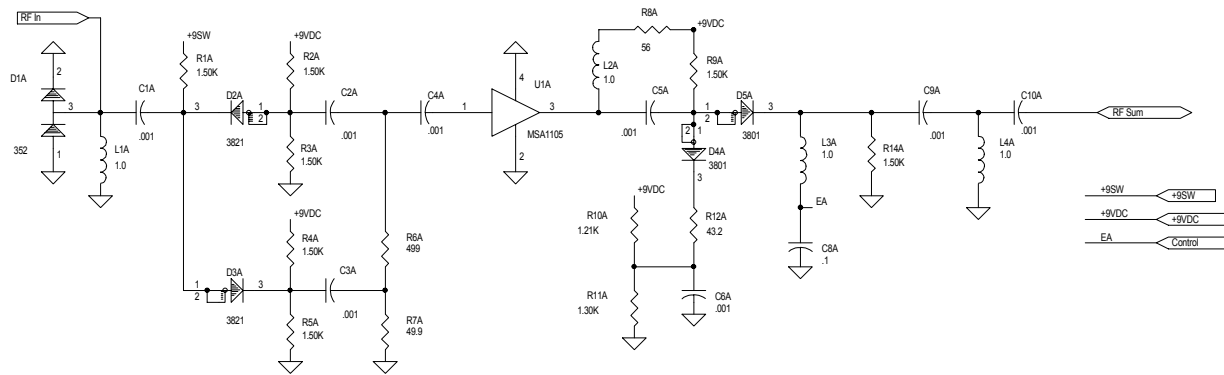

DDF6115
Channel A

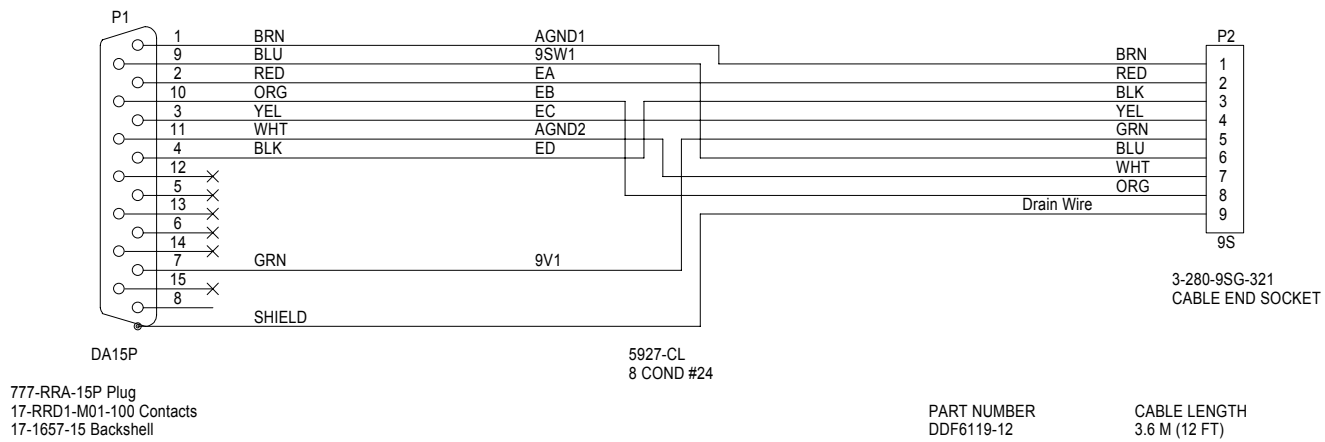

DDF6119
Mobile Control Cable

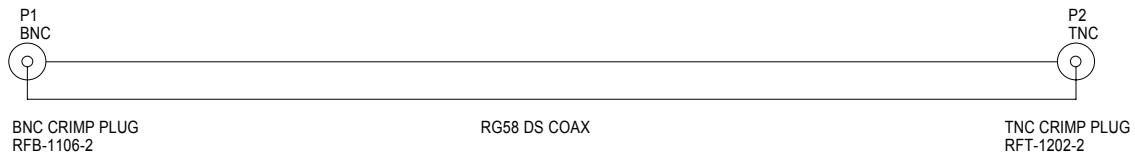

PART NUMBER	CABLE LENGTH
DDF6116-12	3.6 M (12 FT)
DDF6116-25	7.6 M (25 FT)
DDF6116-50	15.2 M (50 FT)
DDF6116-75	22.9 M (75 FT)
DDF6116-100	30.5 M (100 FT)

DDF6116
Coax Cable

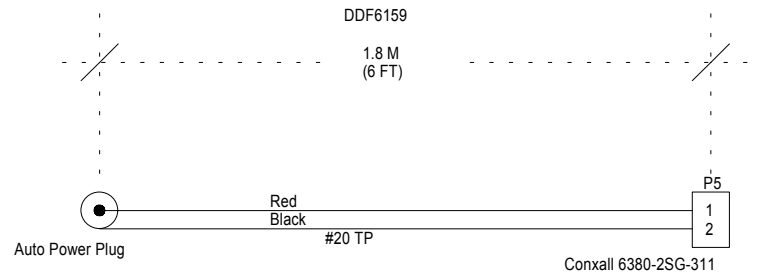
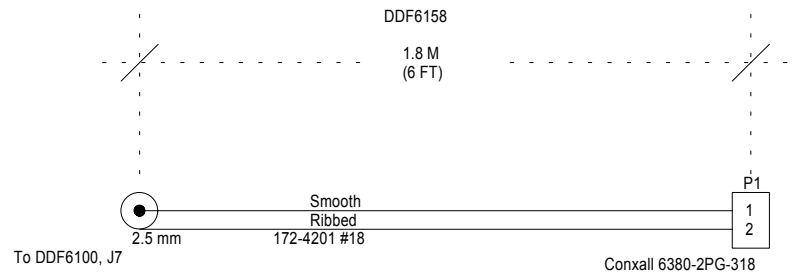
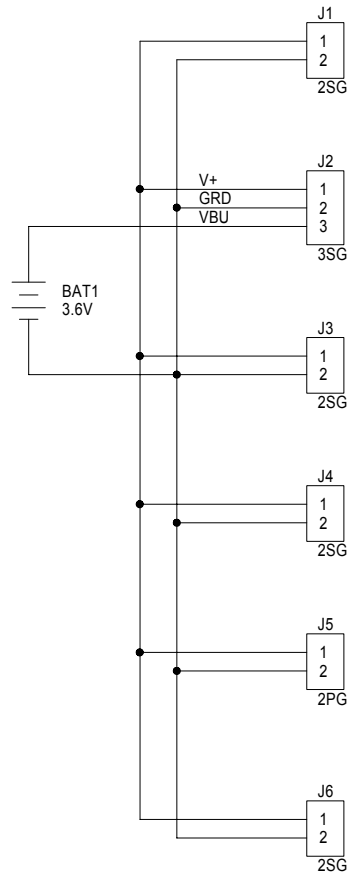

DDF6072
Power Distribution Unit

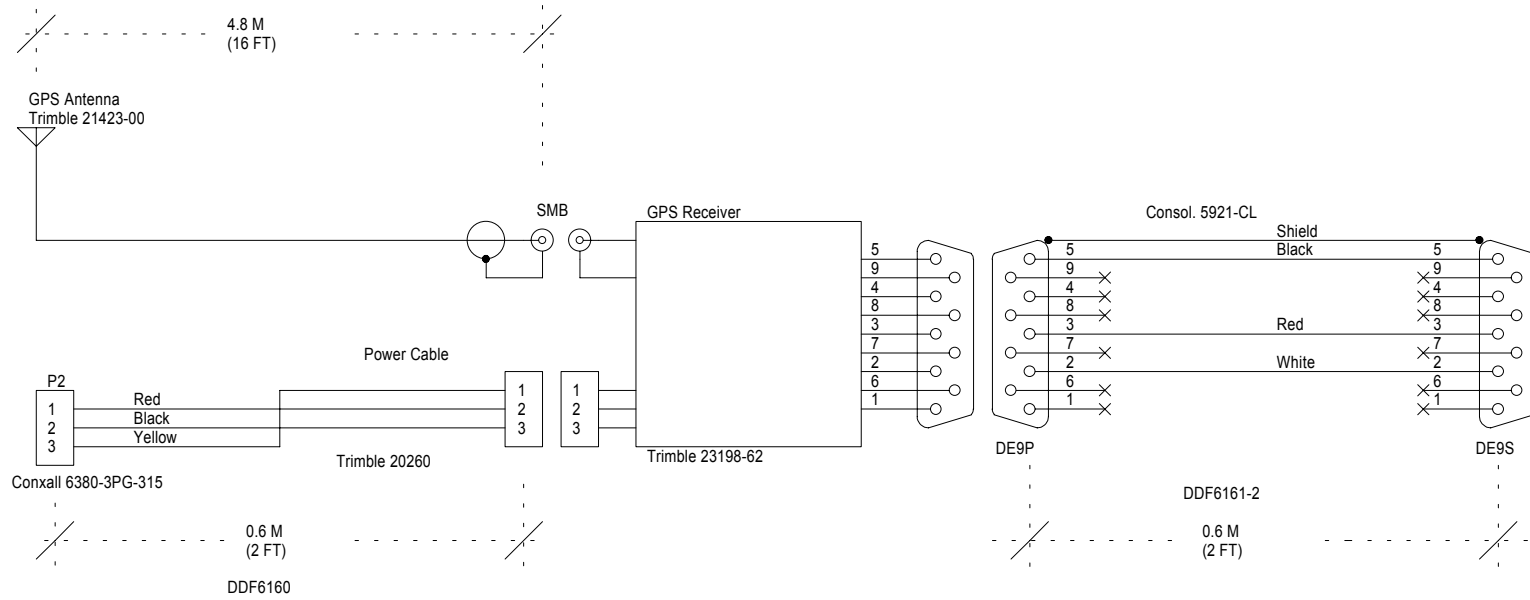

DDF6074 GPS Cabling

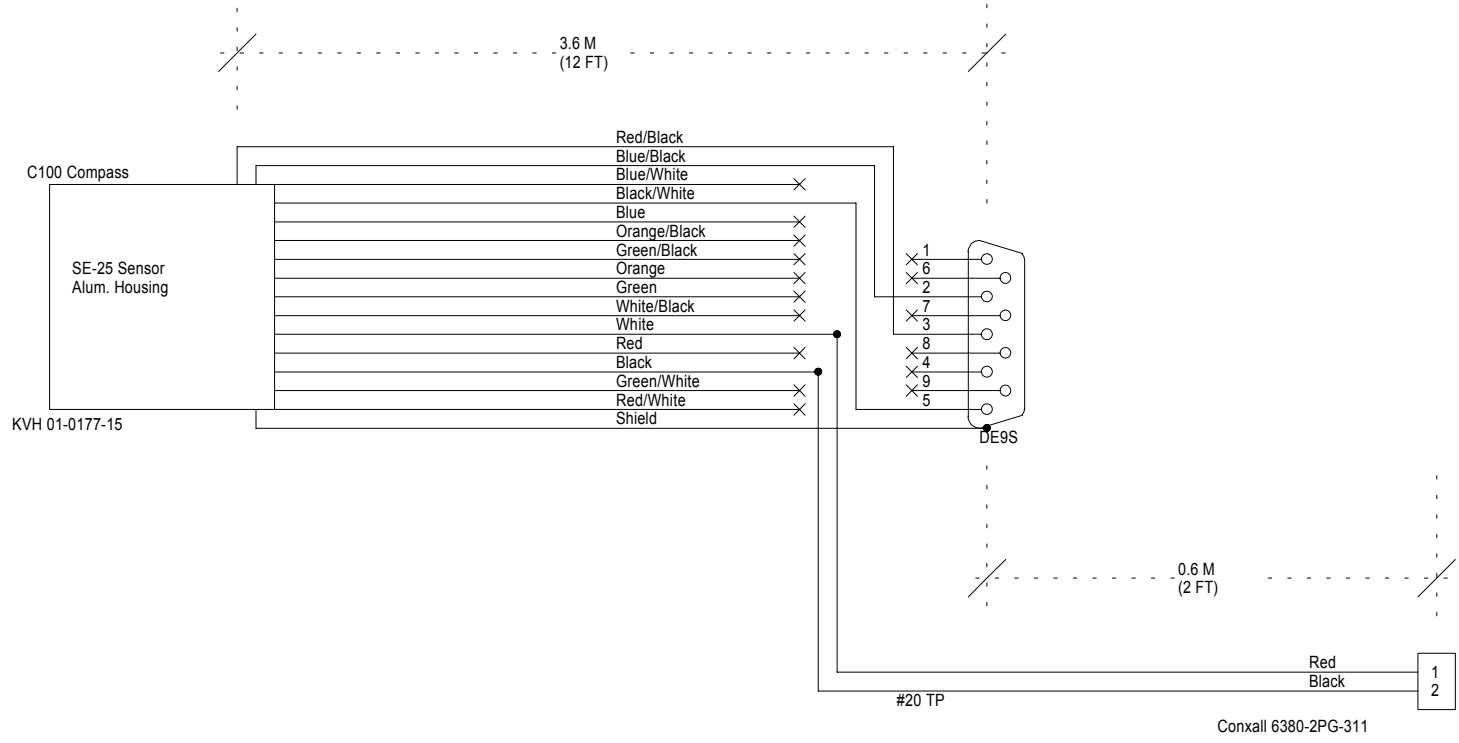

DDF6075
Compass Cabling