

Remote Control and Operation of DDF6000 Direction Finders via YDR24 and EFJ DL3295 Radio Modems

A Technical Application Note from Doppler Systems

June 24, 1998

1.0 Introduction

Either radio modems or telephone line modems may be used to connect a PC located at a control site to remotely located direction finders and receivers. Version 3.x of the DDF6000 firmware and version 2.x of the BrgTrack software require that the radio modems operate in a "data activation" mode at 2400 baud. This is a change from previous versions of the DDF6000 firmware and BrgTrack software which utilized RTS and CTS to control the radio modems at 1200 baud. To check which version of firmware you are using, watch the front panel display of the DDF6000 during power turn-on; to check the software version, use the Help | About BrgTrack menu on the PC. If you need an upgrade, see the Software & Upgrade page on the web site, or seek help from your local distributor or the factory.

2.0 Configuration

A radio modem is required at each remote site and at the control site. All radio modems must be set to the same frequency for both transmission and reception. The "host" radio modem is located at the control site and connects to the PC running BrgTrack. This modem transmits and receives data from each of the remote site radio modems.

A single remote site may be controlled by BrgTrack using two radio modems as indicated in Figure 1, or multiple sites may be connected as shown in Figure 2. There is no limit to the number of sites that may be connected. However, the response time will be reduced as the number of sites increases since it takes about 200 milliseconds to poll each site using radio modems. This would suggest that the number of active sites be limited to about 4 when using radio modems. Note that the response time obtained with leased line telephone modem connection is faster - about 135 milliseconds per site. (For comparison, a direct; i.e., non-modem connection can be polled in about 70 milliseconds).

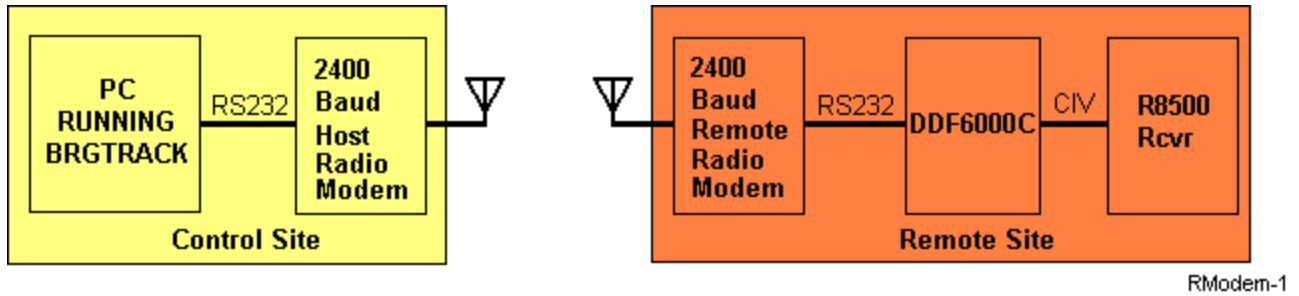

Figure 1

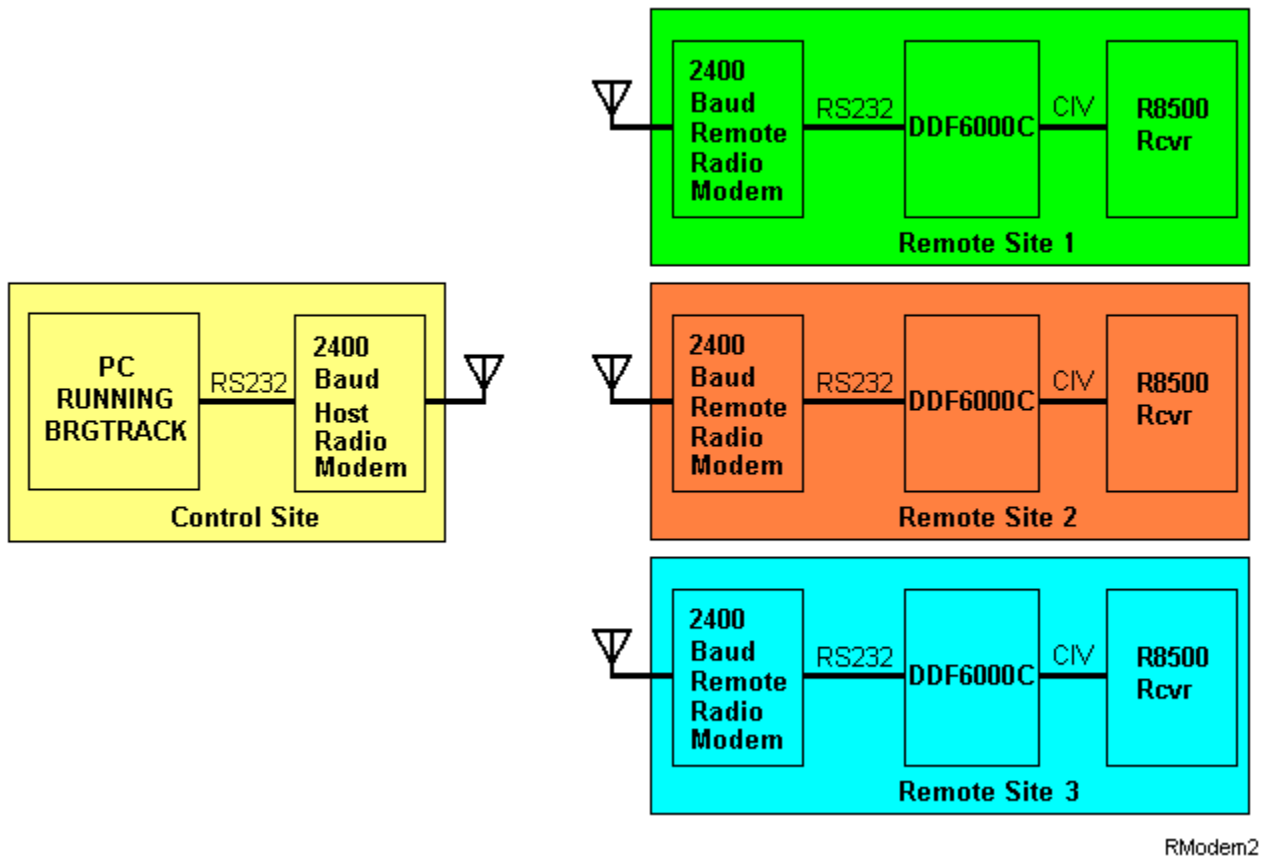

Figure 2

3.0 Choice of Modem

Select modems providing a 2400 baud data activation (3-wire) RS232 interface. Do not mix modems; that is use the same model and manufacturer at the control and all remote sites. We have tested the system with two modems and provide the setup instructions for each in the following sections:

Young Design Inc., 103 Rowell Court, Falls Church, VA 22046, Tel 703-237-9090, for radio modem models 24R-Radio or 24CM-Radio.

E F Johnson Co., PO Box 1240, Waseca, MN 56093, Tel 281-444-8686, for radio modem model 3295.

4.0 Setup for YDI Model 24R or 24CM Radio Modems

Install the software program on a Windows based PC. Connect the PC to the modem using a standard RS232 cable that connects at least TXD, RXD and GRD. Run the program and select the following parameters from the Modem Setup Screen:

Setting	Value
Data rate	2400
Data bits	8
Parity	None
Stop bits	1
Transmitter Operating Mode	Data activation mode
Buffer Delay	50 msec
Transmitter shut off method	After transmitting the end of transmission character
EOT character	Other FD (Hex)
Carrier detect to data delay	10 msec
Anti-streaming timer	Time out after 1 sec

5.0 Setup for E F Johnson Model DL-3295 Radio Modem

These modems are set up using DIP switches located inside the modem. Remove the circuit assembly by removing the four screws at the corners of the front panel, and the four flat head screws on the bottom of the enclosure. Locate the two DIP switches marked S1 and S2. Note that the ON position is towards the inside of the circuit assembly. Set the switches as shown in the following tables:

Switch	Setting for Host modem	Setting for Remote modems
--------	------------------------	---------------------------

S1-1 (RS0)	ON	OFF
S1-2 (RS1)	ON	ON
S1-3 (TTL)	OFF	OFF
S1-4 (TTL)	OFF	OFF
S1-5 (TTL)	OFF	OFF
S1-6 (RS232)	ON	ON
S1-7 (RS232)	ON	ON
S1-8 (RS232)	ON	ON

Switch settings S1-1 and S1-2 provide a delay time at the beginning of transmission of 35 msec at the host and 65 msec at the remote. **Be sure to note which modem is programmed for 35 msec.** The other settings select RS232 levels for the data lines.

Switch	Setting for Host and Remote modems
S2-1 (BR0)	ON
S2-2 (BR1)	OFF
S2-3 (BR-2)	ON
S2-4 (8/9)	OFF
S2-5 (CFG)	OFF
S2-6 (H/F)	ON
S2-7 (H/D)	ON
S2-8 (TOT)	ON

S2-1, 2 and 3 select 2400 baud, S2-4 selects 8 data bits, and S2-5 selects normal (asynchronous data) mode. S2-6 turns the scrambling feature off, S2-7 enables the data activation mode, and S2-8 enables the time out timer.

After setting the DIP switches, reassemble the modem in its case.

6.0 RS232 Wiring

6.1 Host Modem to PC Cable

You can use any standard direct connection RS 232 cable. However, all that is required is a 3 wire shielded cable that connects the host modem to the COM port on the PC.

Signal	PC DB25 (female) pin	PC DE9 (female) pin	Host modem DB25 (male) pin	Host modem DE9 (male) pin
TXD	2	3	2	3
RXD	3	2	3	2
Ground	7	5	7	5

6.2 Remote Modem to DDF6000 Cable

A 3-wire shielded cable is required that connects the following signals on the remote modem to J1 on the DDF6000.

Signal	Remote modem DB25 (male) pin	Remote modem DE9 (male) pin	DDF6000 DE9 (male) pin
TXD	3	2	3
RXD	2	3	2
Ground	7	5	5

7.0 Testing the Modems

Connect a DDF6000 to a remote modem and connect the host modem to the PC. Place a dummy load or short whip antenna in the RF connectors. Turn the modems on.

Be sure that a plug is inserted in J4 on the DDF6000 to place it in the CIV mode. Turn on the power to the direction finder with the plug installed. To test the network, you do not need to have a receiver or direction finder antenna connected. You can place the direction finder in a "self test" mode by selecting (from the front panel) Sweep = 0, Cal = ON, Sig = 9). The DF should display a bearing. When you finish these tests, you can turn off the self test mode using the same command sequence.

Execute BrgTrack on the PC. Check that the proper COM port has been selected (Setup | Serial Port), then check that the DF address matches that of the DDF6000 connected. (The default value is 1). Select Setup | Site, Enable one site, select Modify, and set the DF-id to the address of the DDF6000. If a CIV receiver is connected to the DDF6000, check that its address also matches that shown in the RX-id field. Select Locate on Map and be sure that the site location is shown somewhere on the screen. If a CIV receiver is not connected to the DF, be sure that no channels are enabled (Setup | Channels | Disable).

Now place BrgTrack in the RUN mode. The TXD and RXD lights on both modems should blink and the BrgTrack screen should display a bearing.

To verify that the system will restart after a power failure, turn the DDF6000 Off. BrgTrack will display an error message. Turn the DDF6000 back ON then click on "Yes" to restart BrgTrack's polling sequence.

Turn off the power on the remote modem. BrgTrack will again display an error message. Turn the power back on and wait a few seconds. Now click the "Yes" button to restart BrgTrack.

Turn off the power on the host modem, turn it back on, and wait a few seconds. Restart BrgTrack using the Yes button.

If you will be connecting to multiple sites, repeat the above tests using the next remote site modem.

Before testing multiple modems and DF's you need to set the addresses of each DDF6000 to a unique value using the RDFCMD program provided with the direction finders. Connect a DDF6000 to the PC serial port (using a minimum 3-wire cable), execute RDFCMD, select the proper COM port, select DF serial port J1, select CIV protocol, enter the current CIV address (1 unless you have already changed it), and enter anything for the receiver CIV address.

Enter command 0 (Bearing Data Rqst) and verify that the a response message is received. To change the CIV address, enter command 4 from the Main menu to reach the RDF Address Menu, enter the new CIV address, then hit the ESC key twice to exit the program.

If you will be using CIV receivers at each site, you need to also set unique addresses on these. Refer to the ICOM receiver manual for instructions on setting the CIV addresses.

Connect the host mode modem to the PC and connect a remote site modem to each DDF6000. Attach dummy loads to all RF connectors.

With BrgTrack in its off mode, setup the CIV addresses for the direction finders and receivers at each site to match those connected to the network.

Turn all the direction finders and modems on. Now click on Run in BrgTrack. You should see bearings displayed at each site (assuming that all direction finders are still in the self test mode).

8.0 Timing

The following timing diagrams are provided as an aid in case you experience difficulty with communications after setting up the modems. Figure 3 shows the timing as measured with a YDI Model 24R modem pair. Figure 4 shows the same timing measured using a pair of EF Johnson DL-3295 radio modems.

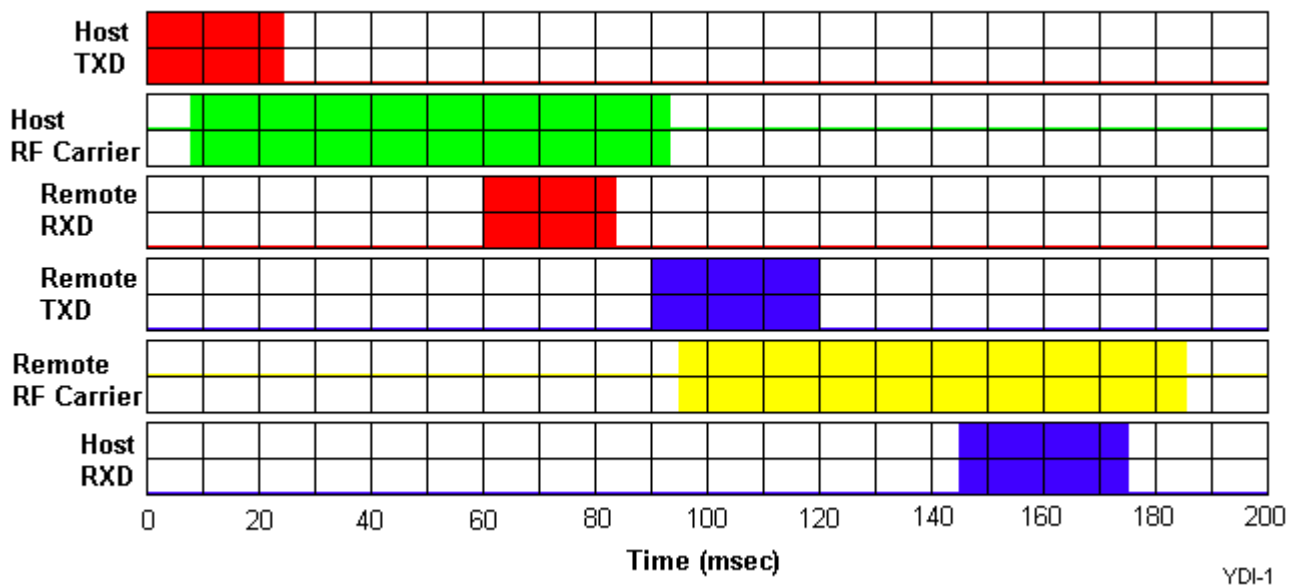

Figure 3

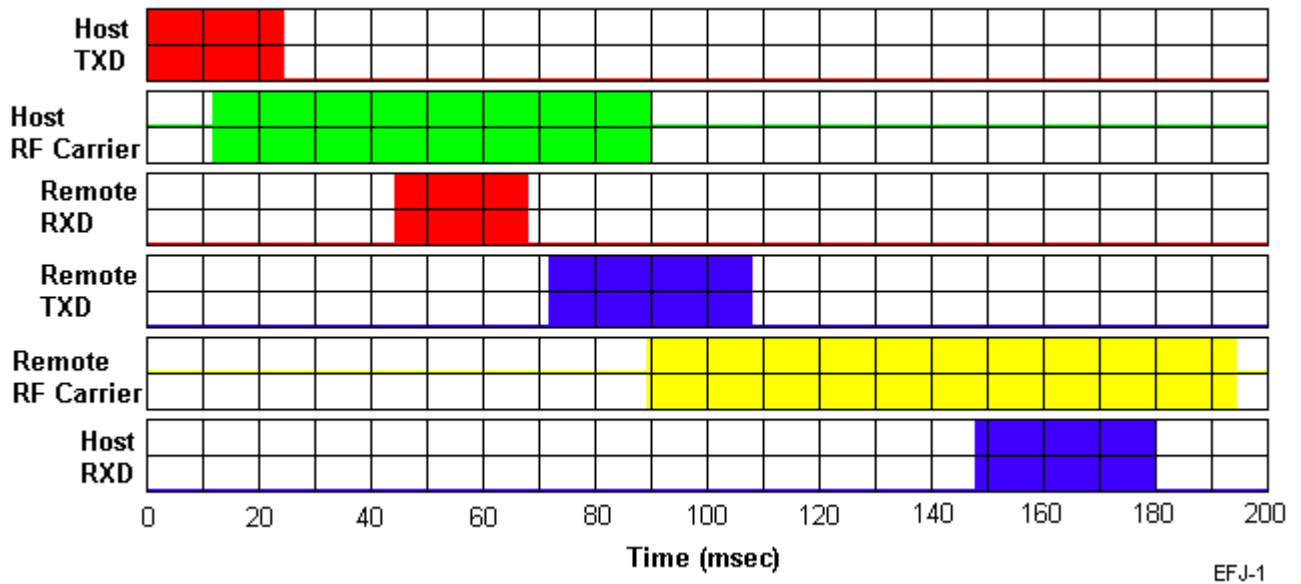

Figure 4

In both cases, the top trace (red) show the bearing request message which is approximately 24 msec long as output by BrgTrack (or RDFCMD). This message is delayed by the host modem buffer, transmitted and presented to the DDF6000 as the third trace (red) labeled Remote TXD. The DDF6000 response is shown as the (blue) trace Remote TXD. This message contains the bearing information and is approximately 30 msec long. This message is again delayed by the remote modem buffer, transmitted, and presented to the PC as the bottom (blue) trace.

9.0 Final Installation

When all of the modems, direction finders, receivers and the PC are operating reliably in the same room using dummy loads on the RF outputs, you are ready to relocate the remote modems, direction finders and receivers to the remote sites and connect them to the radio modem antennas. Be sure to note the CIV addresses of the direction finders and the receivers so that they are installed at the correct site location. Also, be sure not to mix up the host and remote modems. Remember to switch off the self test mode on the direction finders.